



**W. W. Patterson Company**  
**3 Riversea Road**  
**Pittsburgh, PA 15233**  
**Phone: 800-322-2018**  
**FAX: 412-322-2785**

**OPERATIONS/PARTS MANUAL**  
**FOR**  
**PATTERSON'S**  
**MODEL # WWP40E-5-14**  
**ELECTRIC WINCH.**

Please fill in the following blanks and then keep this manual in a safe and convenient location. When calling with either questions or replacement part needs, always refer to the Winch Model, Part Number and Serial Number.

**WINCH PART #: 6052-NC**

**WINCH SERIAL #:** \_\_\_\_\_

**MOTOR MFG.:** \_\_\_\_\_

**MOTOR SERIAL #:** \_\_\_\_\_

**BRAKE SERIAL #:** \_\_\_\_\_

**DATE PURCHASED:** \_\_\_\_\_

**DISTRIBUTOR INFORMATION**

**NAME:** \_\_\_\_\_

**ADDRESS:** \_\_\_\_\_

**CITY:** \_\_\_\_\_ **STATE:** \_\_\_\_\_ **ZIP:** \_\_\_\_\_

**PHONE:** \_\_\_\_\_ **FAX:** \_\_\_\_\_



## **IMPORTANT!**

Prior to installing and operating the winch, please read this manual thoroughly and carefully. Keep this manual and all other instructions accessible at all times.

Although this manual will help you become familiarized with the operating procedures for the winch, it is by no means a substitute for proper training and the safe use of winches, barge rigging and other marine equipment. Because owners and operators are solely responsible for determining whether a particular usage is acceptable, only individuals trained in the proper use of winches, barge rigging and other marine equipment should operate winches.

The typical operational environment of winches includes very high forces, and the potential hazards associated with these forces should not be underestimated. Improper installation or misuse of the winch may result in injury to persons or cause equipment failure or damage.

### **ALWAYS OBSERVE THESE BASIC SAFETY PRECAUTIONS:**

- To reduce potential of electrical shock or other injury, turn off and lock out or tag out power source before initiating any maintenance or repairs.
- Keep all fingers, loose clothing and any foreign objects away from winch while in operation.
- During operation of the winch, always remain to the side of the winch, slightly behind the gear motor.
- Never operate the winch from the front or when bystanders are in front of it.
- Operators and bystanders should stay clear of any load and the wire rope while the winch is operating.
- Under no circumstances, should any winch be used to move, raise or lower a person(s) or equipment.
- Do not operate the winch unless you have a firm stance on a non-slippery surface.
- Do not apply tension to the winch unless there are at least four complete wraps of rope on the drum.
- Motorized operation of the winch with the hand crank engaged in the Motor Shaft is improper and a misuse of the winch. Instead, the hand crank should be stored in its proper place prior to motorized operation.
- Inspect the winch carefully at least once a month for worn gears and pawls, cracked welds, and other damaged parts. If any worn, cracked or damaged parts are found, stop use immediately and remove the winch from service until all appropriate repairs are completely made.

# 1. INSTALLATION

**WARNING! WINCHES SHOULD ONLY BE LIFTED BY THE LIFTING EYES ON EACH SIDE OF THE WINCH. NEVER LIFT THE WINCH BY THE GEARMOTOR OR DAMAGE WILL OCCUR !**



1.1. All winches must be installed on flat, rigid and non-slippery surfaces. Deck and structure must be strong enough to withstand the weight and holding capacity of the winch, and the forces likely to occur during operation.

1.2. Place the winch in the mounting area, in line with the direction of cable pull. Check to make sure there is enough clearance and Fleet Angle Distance for proper operation. (Refer to Diagram on Page 8.)

1.3. Weld to deck along the complete length of both foot mounts. Use seal welding to protect the weld against corrosion. Remember, the weld has to be strong enough to withstand loads equal to, at least, the Ultimate Shock Load Capacity of the winch.

**WARNING! ONLY A QUALIFIED ELECTRICIAN SHOULD WIRE CONTROL BOX AND REMOTE STATION OF A WINCH. W. W. PATTERSON COMPANY IS NOT LIABLE FOR DAMAGE CAUSED BY UNAUTHORIZED OR UNQUALIFIED PERSONNEL ATTEMPTING TO CONNECT A WINCH TO A POWER SOURCE.**

1.4. All winches have been factory wired to 230V unless otherwise specified at time of original purchase. All Electra-Gear motors are equipped with a protective thermostat and all Patterson control boxes are equipped with a thermal switch. All winches have been factory tested prior to shipment to insure proper operation. Assuming the control box and remote station have been properly installed and wired, no further wiring is required except to connect the winch to the control box.

1.5. Open the conduit box located on the motor. The brake and motor have been prewired at the factory and the numbered wires have been grouped according to the voltage of the motor. All Electra-Gear motors, in addition to these bundles, will have two leads from the thermostat.

**WARNING! DO NOT SEPERATE INDIVIDUAL WIRES FROM A BUNDLE. EACH WINCH HAS BEEN FACTORY WIRED TO 230V UNLESS OTHERWISE SPECIFIED AT TIME OF ORIGINAL PURCHASE.**



# 1. INSTALLATION (Cont'd.)

1.6. Connect each of the three wires from the control box to one of the three usable groups of wires in the conduit box. For an Electra-Gear motor, also connect each of the two wires from the thermostat to each of the two wires from the thermal switch. Properly close the cover on the conduit box.



**WARNING! ONLY A QUALIFIED ELECTRICIAN SHOULD PERFORM THIS WIRING. CAUTION MUST BE TAKEN TO CAREFULLY READ AND UNDERSTAND THE WIRING SCHEMATIC FOUND ON THE INSIDE OF THE COVER OF THE CONDUIT BOX.**

1.7. **Disengage the locking dog.** Depressing either the **IN** or **OUT** button on either the control box or the remote station, test to make sure the winch drum turns in the appropriate direction; **the rope must reel in from the bottom of the winch drum.** Should the winch drum turn in the opposite direction than desired, open the conduit box and disconnect two of the wires leading from the control box. Reverse the position of those two wires in respect to their original position. Reconnect each of the two wires to each of the bundle of wires from the winch motor. Close the conduit box. The winch drum should now turn in the proper direction.

**WARNING! TO REDUCE POTENTIAL OF ELECTRICAL SHOCK OR OTHER INJURY, TURN OFF AND LOCK OUT OR TAG OUT POWER SOURCE BEFORE INITIATING ANY MAINTENANCE OR REPAIRS.**

1.8. Coat all gear teeth with heavy-duty gear grease and lubricate both sprockets and the roller chain.

**WARNING! FAILURE TO INSTALL THE VENT PLUG MAY RESULT IN DAMAGE TO THE GEARBOX.**

1.9. The Vent Plug attached to the gearbox prior to shipment must be installed. Remove the Shipping Plug and discard properly, replacing with the Vent Plug. The gearbox must be checked to insure the gearbox is filled to the proper level with oil. Refer to the manufacturer's maintenance manual attached to the Vent Plug.



## 2. ATTACHING THE WIRE ROPE



2.1. Rotate the drum until the cable clamp nuts appear in the slot on the side plate. Using a standard socket wrench with extension, loosen the nuts.

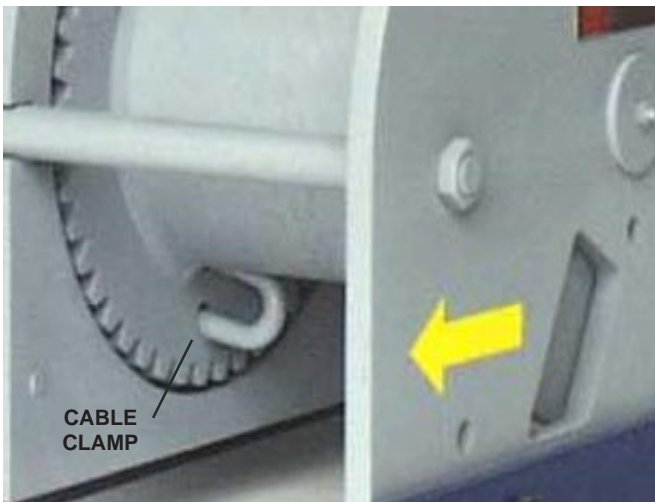

2.2. If installing a new winch, remove and discard the cable clamp spacer. If replacing worn out wire rope, remove the rope from the cable clamp and dispose of the wire rope properly. Insert the new wire rope from the front of the winch into the cable clamp until 3 to 4 inches of rope extends through the clamp. Tighten the nuts evenly.

**WARNING! PERIODICALLY RETIGHTEN THE NUTS ON THE CABLE CLAMP TO INSURE CABLE IS SNUG AGAINST DRUM FLANGE.**

2.3. Slowly start to reel the rope onto the drum. Maintain enough tension on the rope to be sure the first coil begins snugly against the side of the drum and each successive coil is snug against the previous coil. Check to make sure the rope is reeled in from the bottom of the drum.

2.4. Continue to spool the rope until at least four (4) complete coils of wire rope are snugly on the drum.

**WARNING! FOUR (4) COMPLETE COILS OF THE WIRE ROPE MUST BE ON THE DRUM AT ALL TIMES IN ORDER FOR THE WINCH TO ATTAIN ITS FULL HOLDING CAPACITY.**

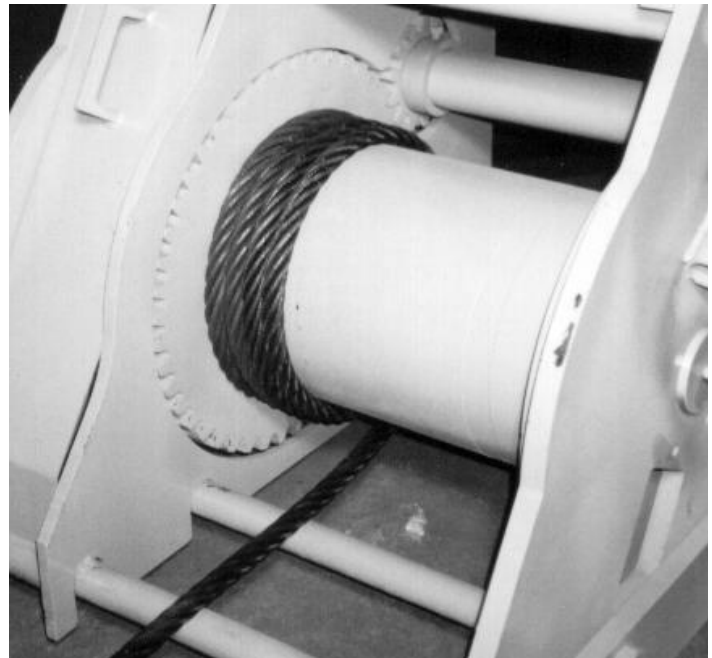

# 3. OPERATION OF WINCH



3.1. The W. W. Patterson electric winch is designed for easier operation and longer life. If sized correctly, installed properly and maintained regularly, this winch will last many years.

3.2. The electric brake, electric motor and gearhead are integrally mounted to the winch frame. Normally, a two button (IN/FORWARD and OUT/REVERSE) control station is used to operate the winch. Each button should be wired in such a way as to provide for automatic stopping the moment either button is released.

**WARNING! ONLY A QUALIFIED ELECTRICIAN SHOULD BE ALLOWED TO WIRE CONTROL BOX AND REMOTE STATION OF A WINCH.**

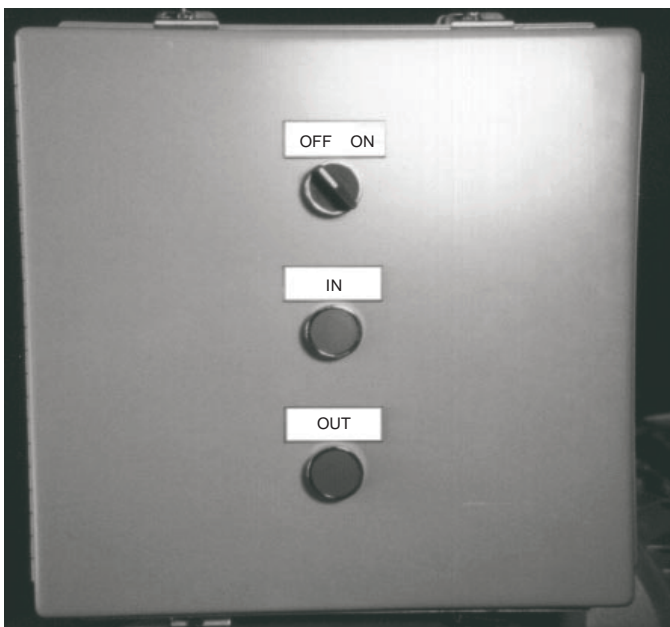

3.3. The electric brake is a disc type, normally set by mechanical spring pressure. It is released automatically when electric power is supplied to its solenoid. In other words, brake release occurs simultaneously with the powering of the motor and the brake locks automatically when the motor's electric power is turned off.

3.4. REEL-IN: Depress the IN/FORWARD push-button. Continue to reel in wire rope at rated load and speed until motor reaches stall. To stop the winch, release the IN/FORWARD button and the brake will engage.

**WARNING! FAILURE TO STOP POWERING THE WINCH AFTER MOTOR REACHES STALL CAN RESULT IN MOTOR BURNOUT.**

3.5. REEL-OUT: Check to see if the Locking Dog is engaged. If it is not, depress the OUT/REVERSE push-button. This will allow for the pay-out of the wire to the desired length. To stop the winch, release the OUT/REVERSE button and the brake will engage. If the Locking Dog is engaged, manually rotate the counterweight towards the back of the winch. Depress the IN/FORWARD push-button until the counterweight rotates the locking dog out of engagement. Release the IN/FORWARD push-button and depress the OUT/REVERSE push-button. This will allow for the pay-out of the wire to the desired length. To stop the winch, release the OUT/REVERSE button and the brake will engage.

3.5.1. If the counterweight does not rotate the locking dog out of engagement the usual cause is that tension on the wire rope exceeds the stall pull of the winch. In this case, reposition the vessel to decrease the tension on the wire rope.

**WARNING! FAILURE TO DISENGAGE THE LOCKING DOG PRIOR TO REELING OUT CAN RESULT IN MOTOR/WINCH FAILURE.**

**WARNING! KEEP ALL FINGERS, LOOSE CLOTHING AND ANY FOREIGN OBJECTS AWAY FROM WINCH WHILE IN OPERATION.**

3.6. Winches supplied with Electra-Gear motors will have a protective thermostat wound into the motor windings. If wired properly (refer to Section 1), the thermostat will protect the motor from over heating. Should the motor reach the preset temperature, the thermostat will shut down the motor causing the winch to stop operating. Wait several minutes to let the motor cool down before proceeding with winch operation.

# 4. EMERGENCY MANUAL OPERATION

**WARNING! MANUAL OPERATION OF AN ELECTRIC WINCH WHILE UNDER LOAD IS EXTREMELY DANGEROUS AND SHOULD ONLY BE DONE IN EMERGENCY SITUATIONS. VERY HIGH TENSIONS ARE COMMON AND THE HAZARDS ASSOCIATED WITH THESE FORCES SHOULD NOT BE UNDERESTIMATED.**

4.1. In the event you lose electric power to your winch, the winch can be operated manually but should only be operated with extreme caution.

**WARNING! TO REDUCE POTENTIAL OF ELECTRICAL SHOCK OR OTHER INJURY, LOCK OUT OR TAG OUT POWER SOURCE BEFORE INITIATING MANUAL OPERATION OF WINCH.**

4.2. To manually release the winch while under load, first lock-out/tag-out the winch, then rotate the counterweight toward the back of the winch. Standing to one side of the winch, release the electric brake ( see separate brake instructions included in this manual ). Remove the shaft extension guard from the rear of the motor, then engage the hand crank on the motor shaft, increase tension on the wire rope until the locking dog lifts out of engagement. **AS THIS OCCURS EXTREME FORCES ON THE HAND CRANK ARE POSSIBLE AND CARE MUST BE TAKEN TO CONTROL THE POTENTIAL REVERSE ROTATION OF THE HAND CRANK.**

4.2.1. If the counterweight does not rotate the locking dog out of engagement the usual cause is that tension on the wire rope is too great to overcome. In this case, reposition the vessel to lessen the tension.

**WARNING! DO NOT STAND IN FRONT OF THE WINCH WHILE RELEASING THE BRAKE.**

**WARNING! W. W. PATTERSON COMPANY DOES NOT RECOMMEND ANY OTHER METHOD OF MANUALLY OPERATING AN ELECTRIC WINCH WHILE THE WINCH IS UNDER LOAD.**

**WARNING! VERY HIGH TENSIONS ARE COMMON AND THE HAZARDS ASSOCIATED WITH THESE FORCES SHOULD NOT BE UNDERESTIMATED.**

4.3. To take up slack: Check to make sure the counterweight is toward the front of the winch and the Load Holding Dog is engaged. Standing to one side of the winch, release the electric brake. Remove the shaft extension guard and engage the hand crank onto the extended end of the motor shaft. Turn the crank to take up the slack of the wire rope. When tension reaches the desired level, maintain pressure on the hand crank while manually engaging the electric brake. Disengage the hand crank from the extended end of the motor shaft and store the hand crank in its proper place, replace the shaft extension guard.

**WARNING! FAILURE TO MAINTAIN PRESSURE ON THE HAND CRANK WHILE RELEASING OR ENGAGING THE BRAKE COULD RESULT IN INJURY.**

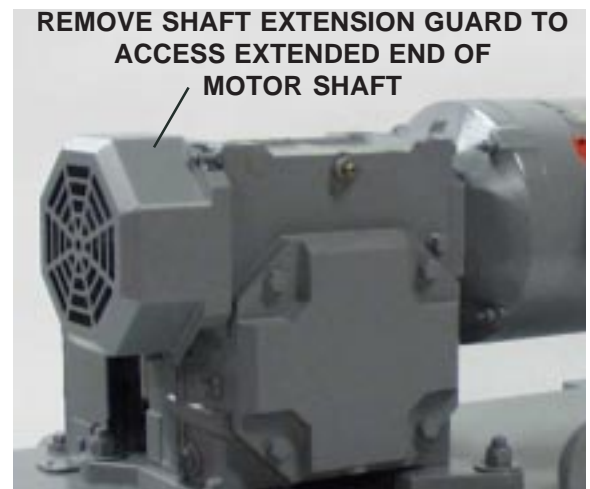

# 5. ELECTRIC BRAKE TROUBLE SHOOTING

**WARNING! ONLY QUALIFIED PERSONNEL SHOULD BE ALLOWED TO INITIATE ANY MAINTENANCE OR REPAIRS.**

**WARNING! TO REDUCE POTENTIAL OF ELECTRICAL SHOCK OR OTHER INJURY, TURN OFF AND LOCK OUT OR TAG POWER SOURCE BEFORE INITIATING ANY MAINTENANCE OR REPAIRS.**

5.1. The electric brake is a disc type brake. The brake is set by mechanical spring pressure and is released automatically when power is supplied to its solenoid.

5.2. The brake has been factory wired, adjusted and tested prior to shipment.

5.3. Over time replacement of brake components may be required. Common problems and their potential solutions are as follows:

5.4. **FAILURE TO STOP** - If the brake does not stop properly, it is usually due to friction disc or hub problems.

5.4.1. Check to see if friction discs are severely worn/broken and are in need of replacement

5.4.2. Check to see if hub has shifted on shaft and is in need of alignment adjustment.

5.5. **EXCESSIVE HUMMING** - If excessive humming is heard coming from the brake, it is usually due to plunger or coil problems.

5.5.1. Clean dirt or foreign matter from between plunger, plunger guide and coil.

5.6 **FAILURE TO RELEASE** - If brake fails to release, it is usually due to wiring or coil failure.

5.6.1. Check to see if there is a broken lead.

5.6.2. Check the voltage coming into the brake. If the voltage is low, the plunger will not seat completely and could cause coil failure.

5.6.3. Check for coil failure. If so, replace.

**WARNING! FOR FURTHER INFORMATION, REFER TO THE ELECTRIC BRAKE PARTS LIST AND SERVICE INSTRUCTIONS INCLUDED ELSEWHERE IN THIS MANUAL.**

STEARNS BRAKE

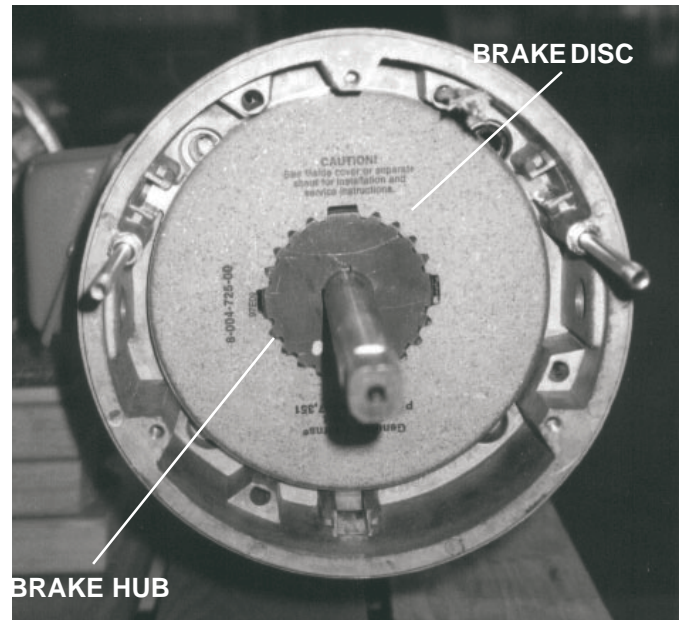

DINGS BRAKE



# 6. LUBRICATION AND INSPECTION

6.1. All grease fittings should be lubricated **regularly** using a **POLYUREA** grease such as ALTRA 500 EP2.

6.2. All gear teeth should be coated **regularly** with heavy-duty gear grease.

6.3. **Regularly**, inspect the winch carefully and completely for worn gears and pawls, cracked welds and other damaged or worn parts. If any worn, cracked or damaged parts are found, stop use immediately and remove the winch from service until all appropriate repairs are completely performed.

6.4. **Regularly**, check roller chain tension. Correct tension is movement back and forth of the roller chain, when pushed and pulled by hand, between 3/4" and 1". Adjust top-plate bolts until correct tension is achieved.

6.5. **Regularly**, oil roller chain using brush or spout can.

6.6 **During the winter months** if the winch runs sluggishly the oil in the gear box could need changing. All winches are shipped from the factory with the gear box filled to 85% capacity with Mobil 600W Lube. The following table shows recommended lubricants and their operating ambient temperature range.

| Lubricant              | Ambient Temp. Range |
|------------------------|---------------------|
| Electra M80 Lube       | +50 to +125         |
| Electra Lube           | +15 to +125         |
| Kendall-Three Star     | -10 to +100         |
| Mobil-Mobil 600W       | 32 to +100          |
| Mobil-Mobil SHC 629    | -25 to +100         |
| Mobil-Mobil SHC 626    | -40 to +40          |
| Conoco-Polar Start 600 | -40 to +10          |
| Lubr. Eng.-Almasol 606 | -10 to +40          |
| Mobil-Mobil SHC 624    | -55 to 0            |
| Mobil-Mobilgear 627    | -10 to +40          |
| Shell-Donax A.T.F. T-6 | -55 to +5           |

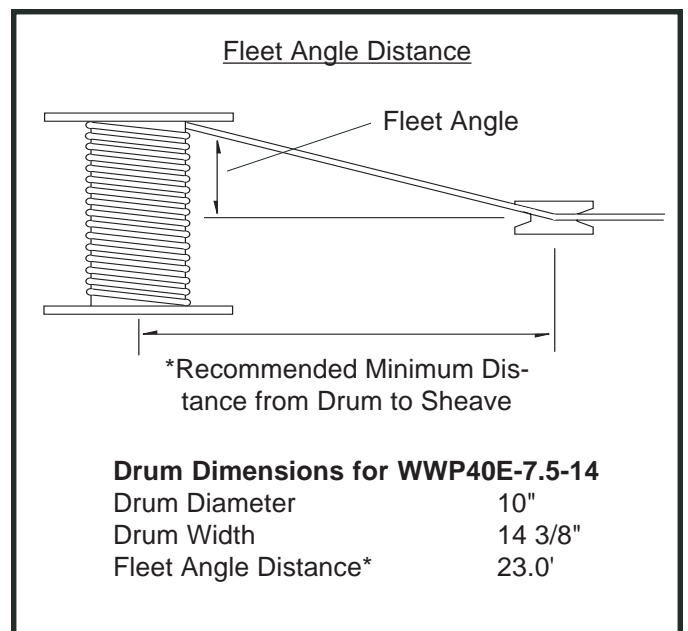
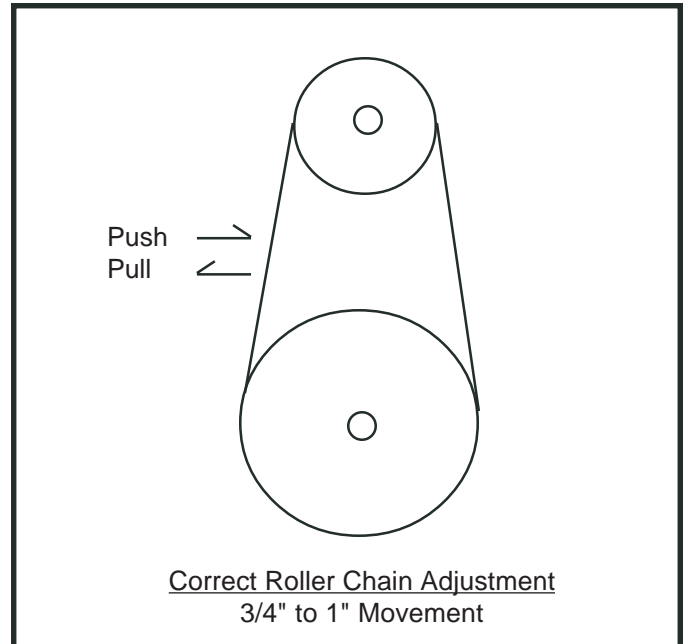

**W. W. PATTERSON COMPANY**

3 Riversea Road, Pittsburgh, PA 15233 • Phone (800) 322-2018 • Fax (412) 322-2785

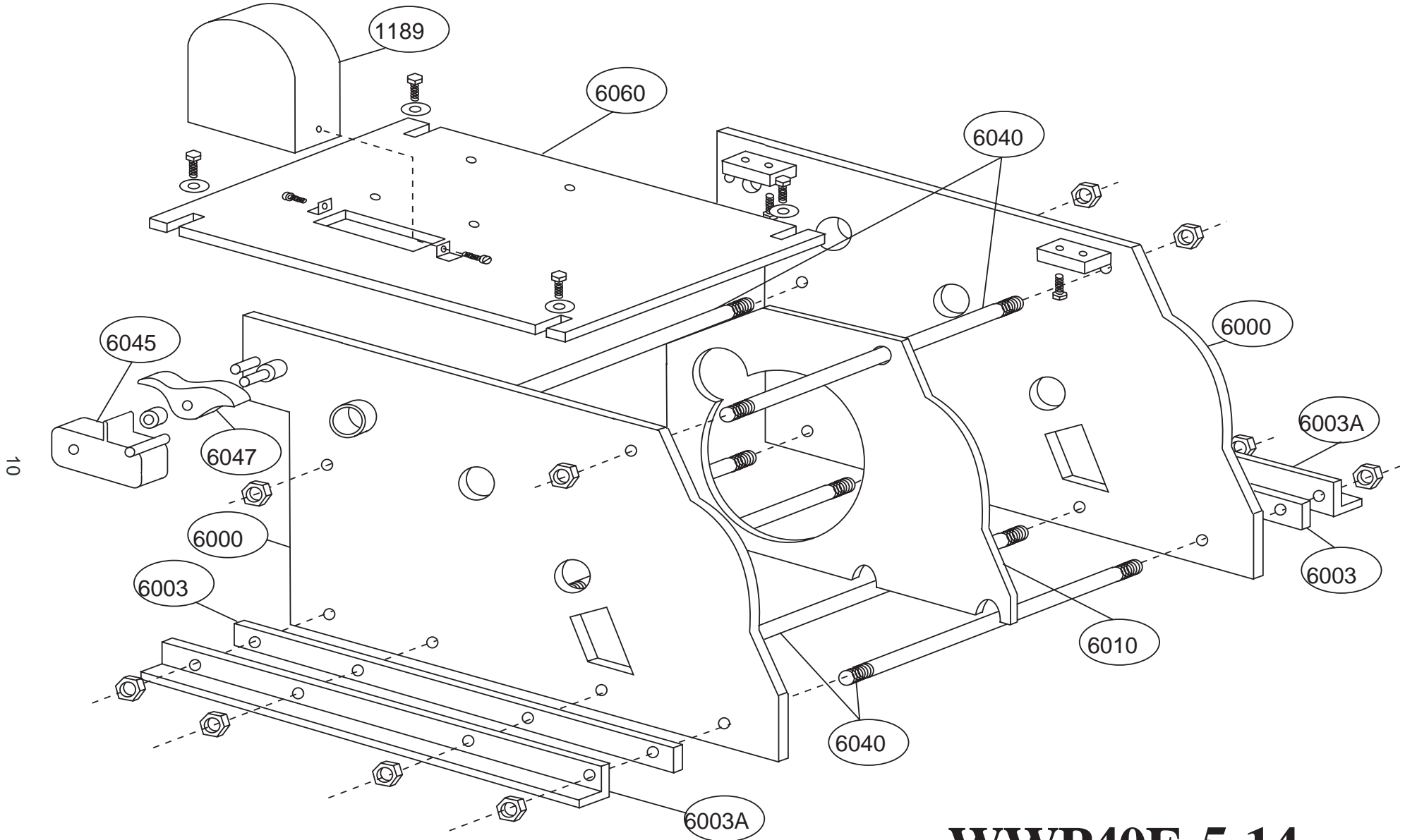

# WWP40E-5-14 Frame Components

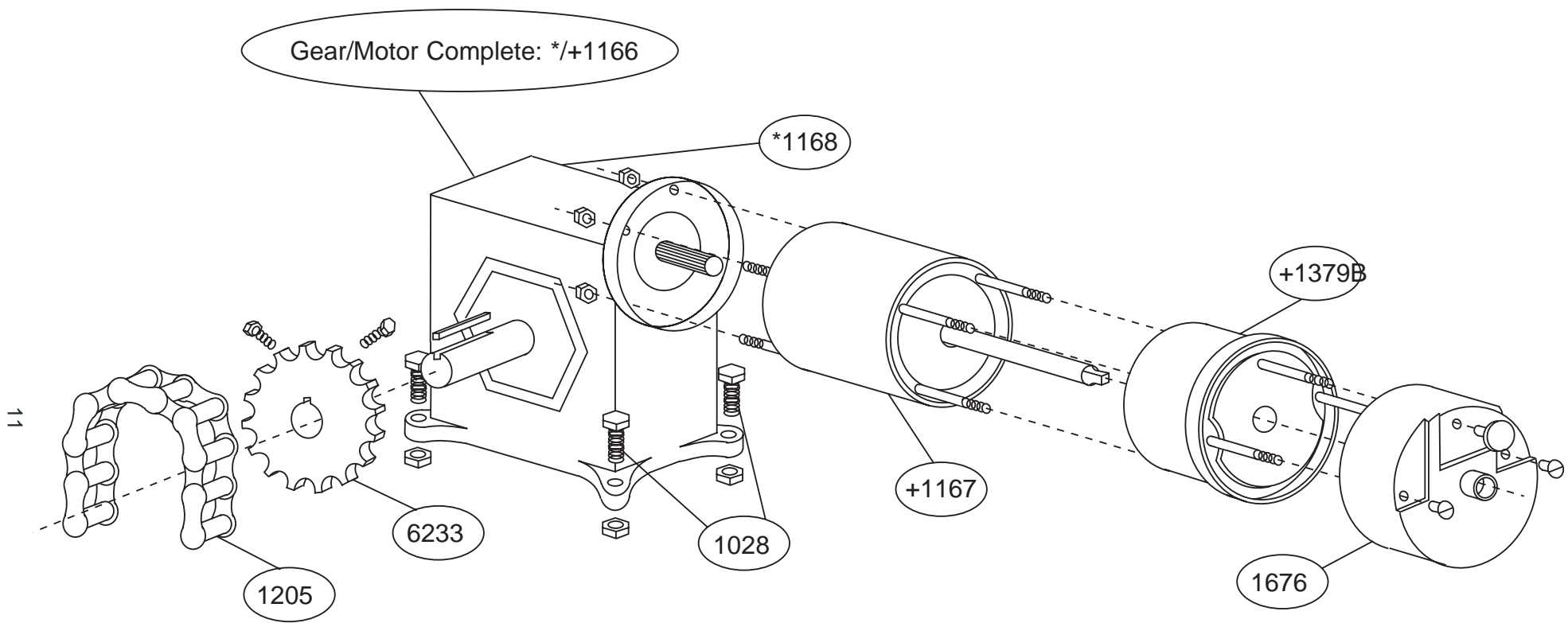

\* When ordering, please note whether left-hand or right-hand.  
 + When ordering, please note whether 230/460 volt or 208 volt.

# WWP40E-5-14 Gear/Motor/Brake Components

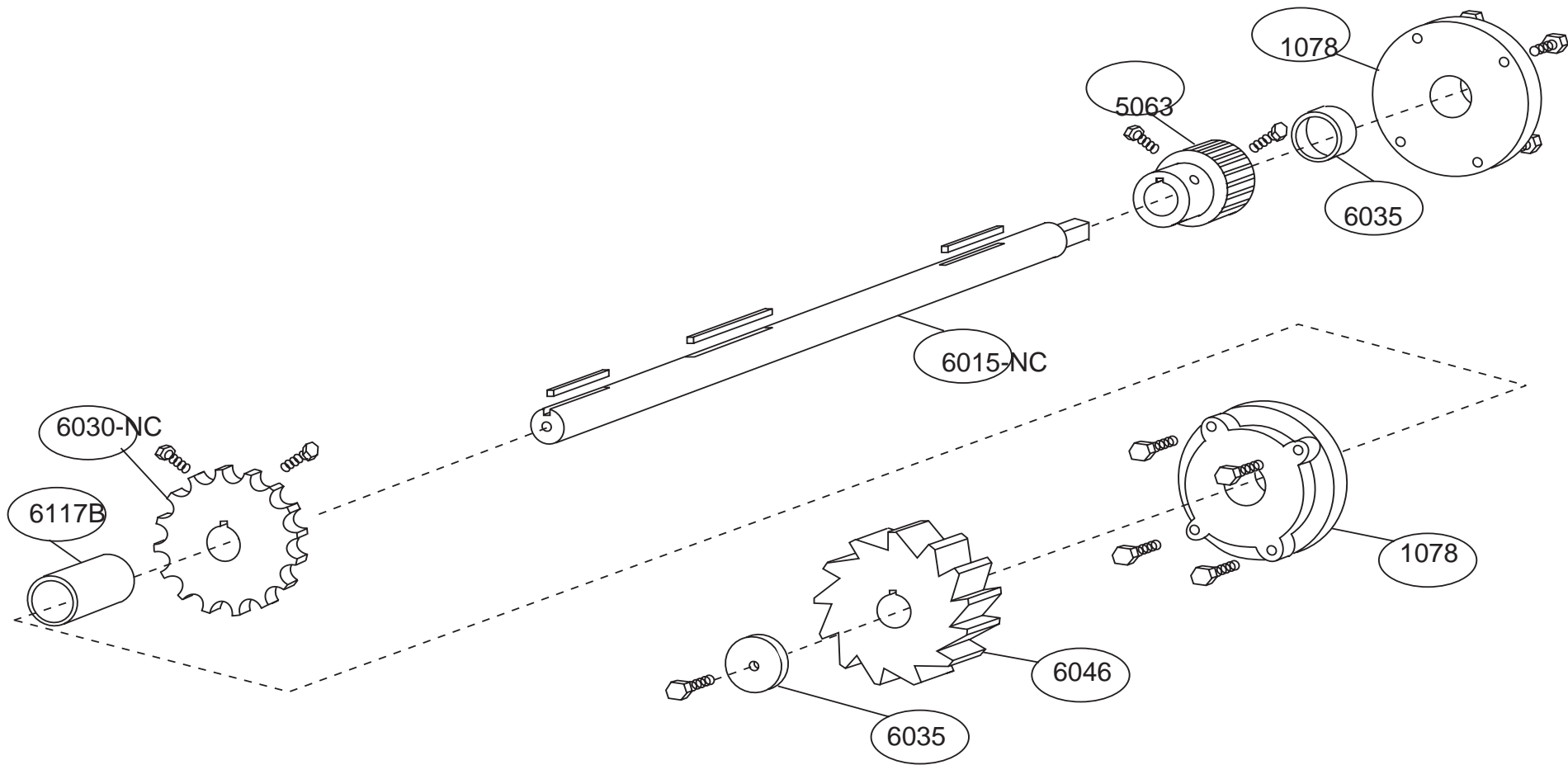

# WWP40E-5-14 #1 Shaft Components

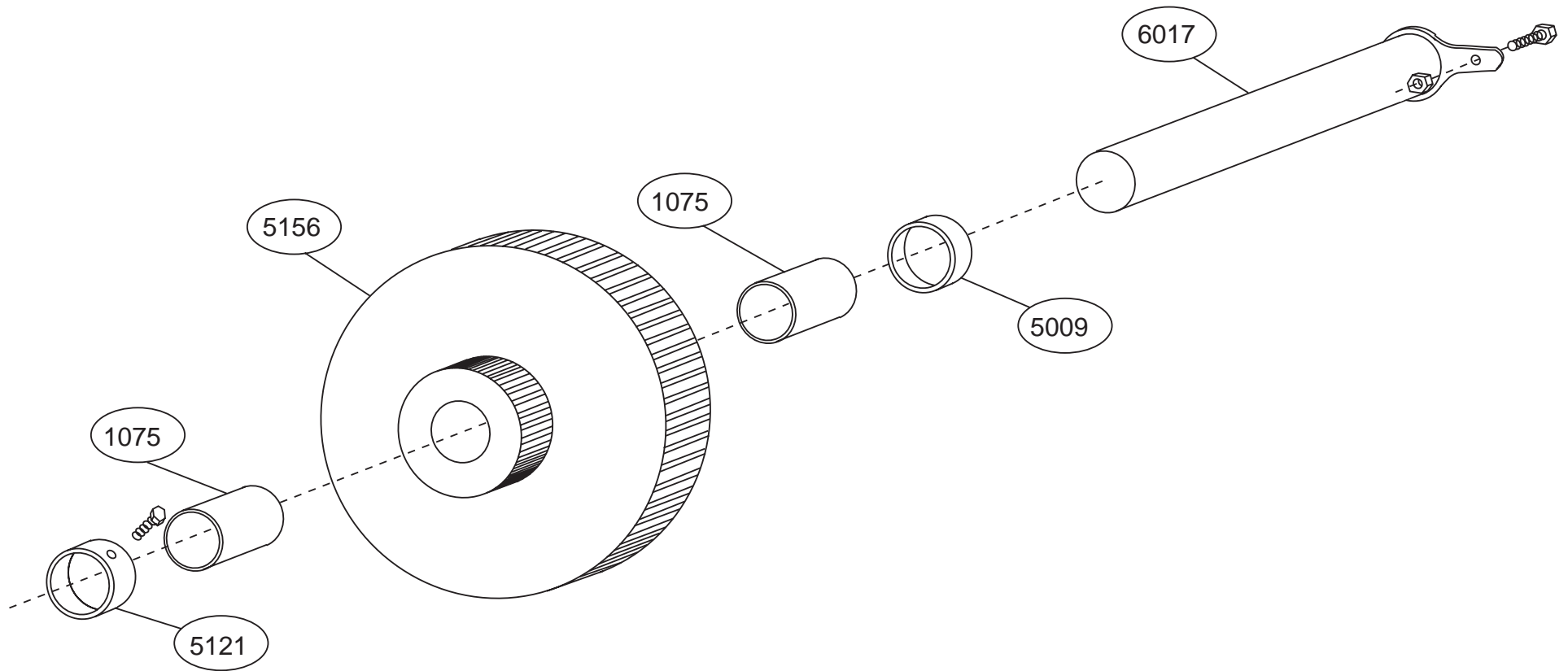

# WWP40E-5-14 #2 Shaft Components

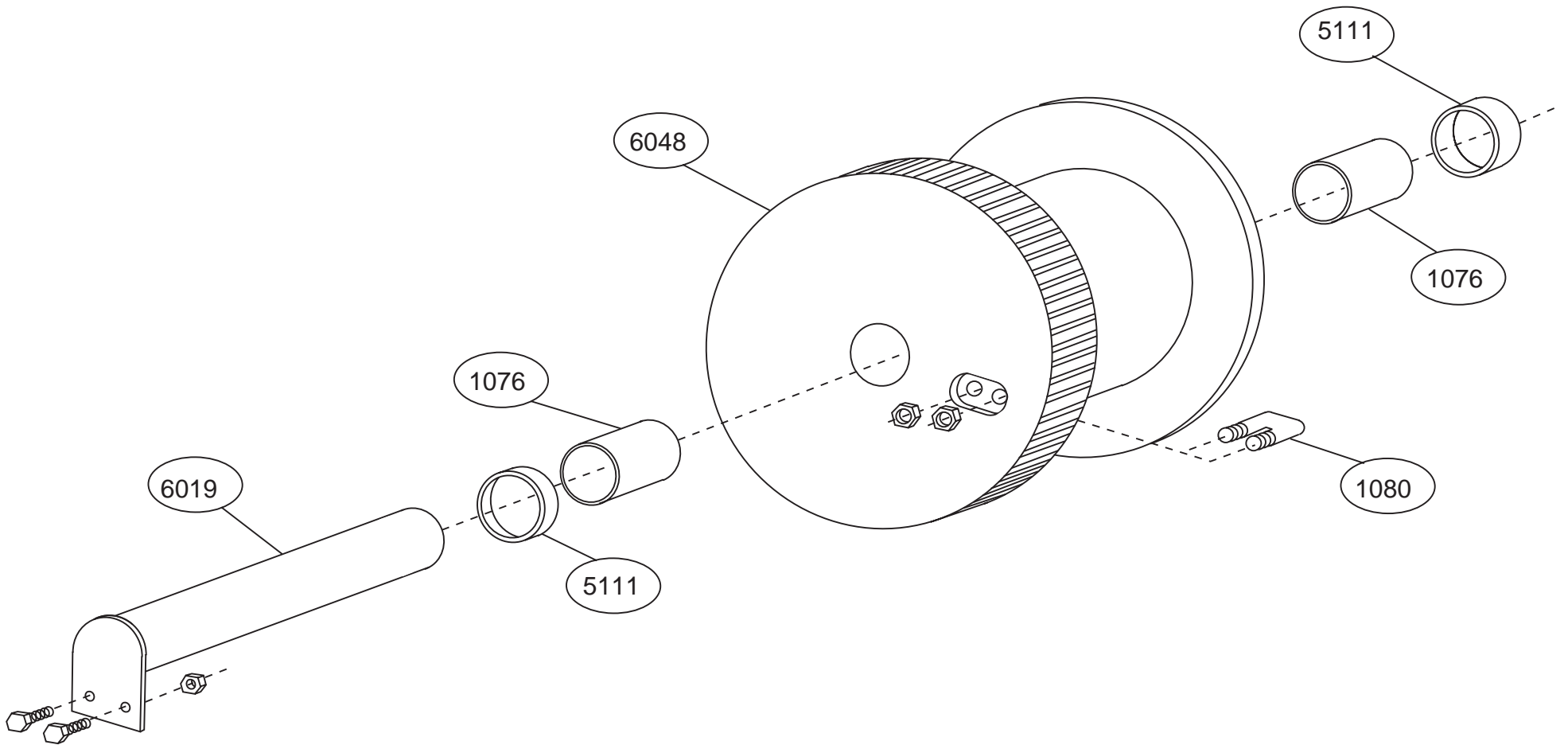

# WWP40E-5-14 #3 Shaft Components

# WWP40E-5-14 WINCH PARTS LIST

## Frame Components

| <u>QUANTITY</u> | <u>DESCRIPTION</u>     | <u>PART NUMBER</u> |
|-----------------|------------------------|--------------------|
| 2               | Side Plate             | 6000               |
| 1               | Rope Guard             | 6010               |
| 1               | Locking Dog            | 6047               |
| 1               | Counter Weight         | 6045               |
| 2               | Foot Mount             | 6003               |
| 2               | Angle Foot Mount       | 6003A              |
| 1               | Motor Base Plate       | 6004               |
| 7               | Seperator Tube/Tie Rod | 6040               |
| 1               | Sprocket Guard         | 1189               |

## Gear/Motor/Brake Components

| <u>QUANTITY</u> | <u>DESCRIPTION</u>      | <u>PART NUMBER</u> |
|-----------------|-------------------------|--------------------|
| 1               | Gear/Motor Complete */+ | 1166               |
| 1               | Motor Only +            | 1167               |
| 1               | Gear Box Only *         | 1168               |
| 1               | Motor Sprocket          | 6056               |
| 1               | Roller Chain            | 1205               |
| 4               | Tie Down Bolts          | 1028               |
| 1               | Brake Cover             | 1676               |
| 1               | Brake - Complete **/+   | 1379               |

\* When ordering, please note whether left-hand or right-hand.

\*\* To order individual Stearns Brake components, refer to Stearns' Parts List included elsewhere in this manual.

+ When ordering, please note whether 230/460 volt or 208 volt.

# WWP40E-5-14 WINCH PARTS LIST

---

## #1 Shaft Components

| <u>QUANTITY</u> | <u>DESCRIPTION</u> | <u>PART NUMBER</u> |
|-----------------|--------------------|--------------------|
| 1               | Shaft              | 6015-NC            |
| 1               | Pinion Gear        | 5063               |
| 2               | Roller Bearing     | 1078               |
| 1               | Sprocket           | 6030-NC            |
| 1               | Large Spacer       | 6035A              |
| 2               | Small Spacer       | 6035               |
| 1               | Locking Dog Gear   | 6046               |

## #2 Shaft Components

| <u>QUANTITY</u> | <u>DESCRIPTION</u>           | <u>PART NUMBER</u> |
|-----------------|------------------------------|--------------------|
| 1               | Shaft                        | 6017               |
| 1               | Combination Spur/Pinion Gear | 5156               |
| 2               | Bushing                      | 1075               |
| 1               | Retaining Collar             | 5121               |
| 1               | Spacer                       | 5009               |

## #3 Shaft Components

| <u>QUANTITY</u> | <u>DESCRIPTION</u> | <u>PART NUMBER</u> |
|-----------------|--------------------|--------------------|
| 1               | Shaft              | 6019               |
| 1               | Rope Drum          | 6048               |
| 2               | Bushing            | 1076               |
| 2               | Spacer             | 5111               |
| 1               | Rope Clip          | 1080               |

