



W. W. Patterson Company
3 Riversea Road
Pittsburgh, PA 15233
Phone: 800-322-2018
FAX: 412-322-2785

OPERATIONS/PARTS MANUAL
FOR
PATTERSON'S
WWP40-H-14
HYDRAULIC WINCH.

Please fill in the following blanks and then keep this manual in a safe and convenient location. When calling with either questions or replacement part needs, always refer to the Model and Serial Number of the winch.

WINCH MODEL #: _____ **WINCH SERIAL #:** _____

MOTOR MFG.: _____ **MOTOR SERIAL #:** _____

BRAKE SERIAL #: _____ **DATE PURCHASED:** _____

DISTRIBUTOR INFORMATION

NAME: _____

ADDRESS: _____

CITY: _____ **STATE:** _____ **ZIP:** _____

PHONE: _____ **FAX:** _____



IMPORTANT!

Prior to installing and operating the winch, please read this manual thoroughly and carefully. Keep this manual and all other instructions accessible at all times.

Although this manual will help you become familiarized with the operating procedures for the winch, it is by no means a substitute for proper training and the safe use of winches, barge rigging and other marine equipment. Because owners and operators are solely responsible for determining whether a particular usage is acceptable, only individuals trained in the proper use of winches, barge rigging and other marine equipment should operate winches.

The typical operational environment of winches includes very high forces, and the potential hazards associated with these forces should not be underestimated. Improper installation or misuse of the winch may result in injury to persons or cause equipment failure or damage.

ALWAYS OBSERVE THESE BASIC SAFETY PRECAUTIONS:

- To reduce potential of injury, turn off and lock out or tag out power source before initiating any maintenance or repairs.
- Keep all fingers, loose clothing and any foreign objects away from winch while in operation.
- During operation of the winch, always remain to the side of the winch, slightly behind the gear motor.
- Never operate the winch from the front or when bystanders are in front of it.
- Operators and bystanders should stay clear of any load and the wire rope while the winch is operating.
- Under no circumstances, should any winch be used to move, raise or lower a person(s) or equipment.
- Do not operate the winch unless you have a firm stance on a non-slippery surface.
- Do not apply tension to the winch unless there are at least four complete wraps of rope on the drum.
- Motorized operation of the winch with the hand crank engaged in the Number One Shaft is improper and a misuse of the winch. Instead, the hand crank should be placed in its designated place prior to motorized operation.
- Inspect the winch carefully at least once a month for worn gears and pawls, cracked welds, and other damaged parts. If any worn, cracked or damaged parts are found, stop use immediately and remove the winch from service until all appropriate repairs are completely made.

1. INSTALLATION

1.1. All winches must be installed on flat, rigid and non-slippery surfaces. Deck and structure must be strong enough to withstand the weight and holding capacity of the winch, and the forces likely to occur during operation.

1.2. Place the winch in the mounting area, in line with the direction of cable pull. Check to make sure there is enough clearance and Fleet Angle Distance for proper operation. (Refer to Diagram on Page 7.)

1.3. Weld to deck along the complete length of both foot mounts. Use seal welding to protect the weld against corrosion. Remember, the weld has to be strong enough to withstand loads equal to, at least, the Brake/Dog Holding Capacity of the winch.

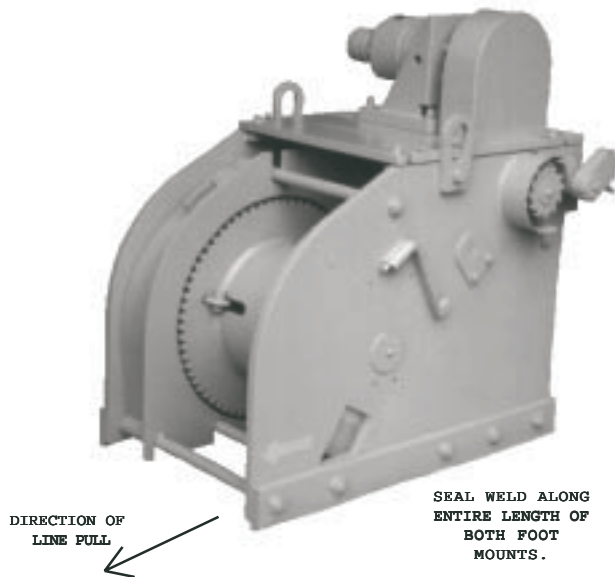

WARNING! ONLY SOMEONE QUALIFIED IN HYDRAULICS SHOULD BE ALLOWED TO PLUMB THE WINCH. W. W. PATTERSON COMPANY IS NOT LIABLE FOR DAMAGE CAUSED BY UNAUTHORIZED OR UNQUALIFIED PERSONNEL ATTEMPTING TO PERFORM SUCH WORK.

WARNING! MOTOR FAILURE MAY OCCUR IF THE HYDRAULIC OIL FLOW EXCEEDS 20 GPM, THE INTERMITTENT PRESSURE EXCEEDS 2,500 PSI AND THE CONTINUOUS PRESSURE EXCEEDS 2,000 PSI.

1.4. Prior to operation, test to make sure the winch drum turns in the appropriate direction; **the rope must reel in from the bottom of the winch drum.** Should the winch drum turn in the opposite direction than desired, replumb the winch. The winch drum should now turn in the proper direction.

1.5. Coat all gear teeth with heavy-duty gear grease and lubricate both sprockets and the roller chain.

1.6. The gear reducer must be filled with EP-90 gear oil or suitable equivalent recommended by a quality lubricant manufacturer.

WARNING! FAILURE TO FILL THE GEAR REDUCER PER THE INSTRUCTIONS WILL RESULT IN CATASTROPHIC FAILURE OF THE GEAR REDUCER.

2. ATTACHING THE WIRE ROPE

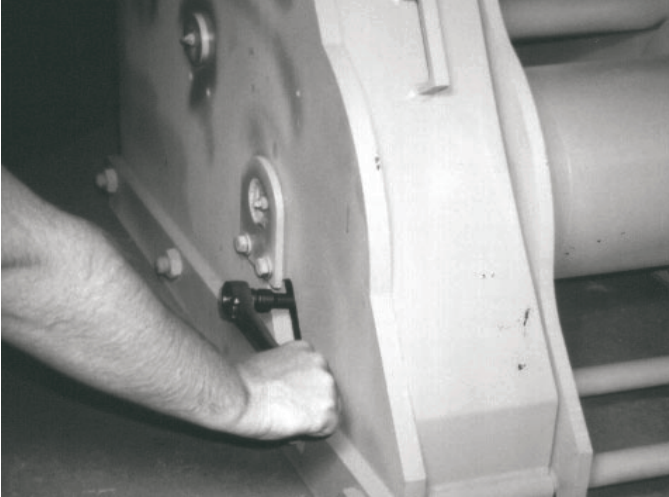

2.1. Rotate the drum until the cable clamp nuts appear in the slot on the side plate. Using a standard socket wrench with extension, loosen the nuts.

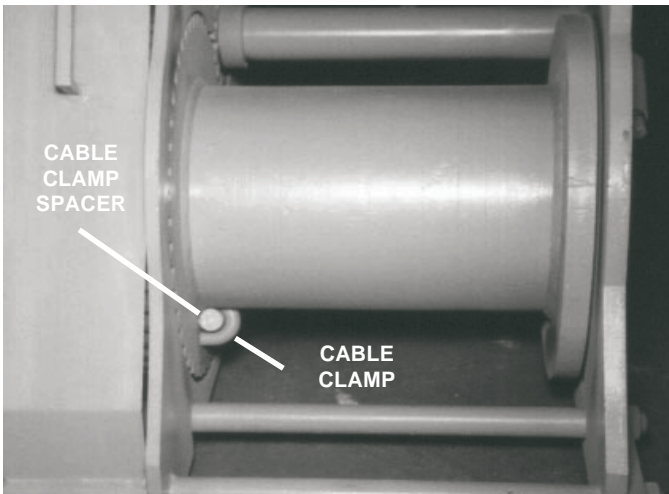

2.2. If installing a new winch, remove and discard the cable clamp spacer. If replacing worn out wire rope, remove the rope from the cable clamp and dispose of the wire rope properly. Insert the new wire rope from the front of the winch into the cable clamp until 3 to 4 inches of rope extends through the clamp. Tighten the nuts evenly.

WARNING! PERIODICALLY RETIGHTEN THE NUTS ON THE CABLE CLAMP TO INSURE CABLE IS SNUG AGAINST DRUM FLANGE.

2.3. Slowly start to reel the rope onto the drum. Maintain enough tension on the rope to be sure the first coil begins snugly against the side of the drum and each successive coil is snug against the previous coil. Check to make sure the rope is reeled in from the bottom of the drum.

2.4. Continue to spool the rope until at least four (4) complete coils of wire rope are snugly on the drum.

WARNING! FOUR (4) COMPLETE COILS OF THE WIRE ROPE MUST BE ON THE DRUM AT ALL TIMES IN ORDER FOR THE WINCH TO ATTAIN ITS FULL HOLDING CAPACITY.

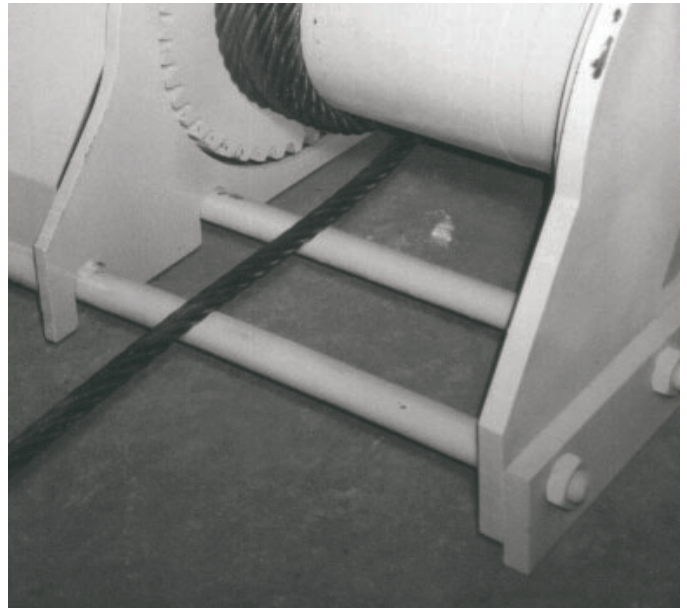

3. OPERATION OF WINCH

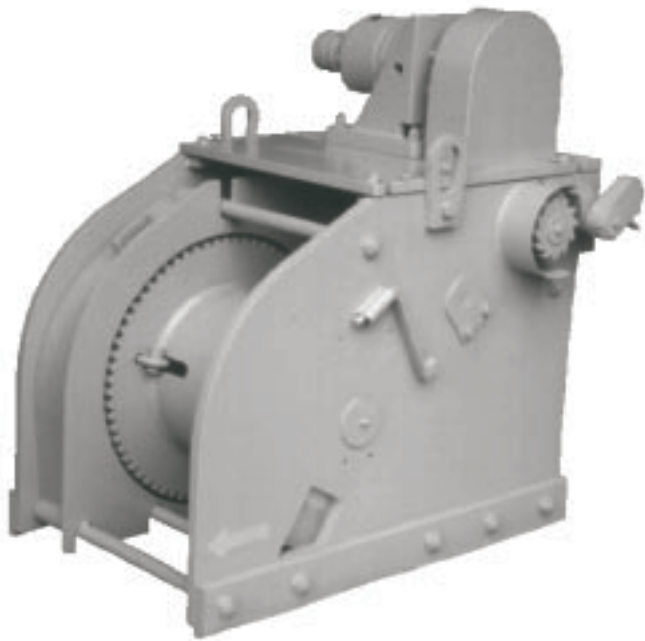

3.1. The W. W. Patterson hydraulic winch is designed for easier operation and long life. If sized correctly, installed properly and maintained regularly, this winch will last many years.

3.2. The hydraulic brake is a disc type, normally set by mechanical spring pressure. It is released by hydraulic pressure.

3.3. REEL-OUT: Check to see if the Locking Dog is engaged. If it is not, pay-out the wire to the desired length. If the Locking Dog is engaged, manually rotate the counterweight towards the back of the winch. Reel in the winch until the counterweight rotates the locking dog out of engagement. Pay-out of the wire to the desired length.

3.3.1. If the counterweight does not rotate the locking dog out of engagement the usual cause is that tension on the wire rope exceeds the stall pull of the winch. In this case, reposition the equipment to decrease the tension on the wire rope and then repeat 3.3.

WARNING! FAILURE TO DISENGAGE THE LOCKING DOG PRIOR TO REELING OUT CAN RESULT IN MOTOR/WINCH FAILURE.

WARNING! KEEP ALL FINGERS, LOOSE CLOTHING AND ANY FOREIGN OBJECTS AWAY FROM WINCH WHILE IN OPERATION.

4. LUBRICATION AND INSPECTION

5.1. All grease fittings should be lubricated **once a week** using a heavy-duty grease such as Keystone Moly 29.

5.2. All gear teeth should be coated **once a week** with heavy-duty gear grease.

5.3. **At least once a month**, inspect the winch carefully and completely for worn gears and pawls, cracked welds and other damaged or worn parts. If any worn, cracked or damaged parts are found, stop use immediately and remove the winch from service until all appropriate repairs are completely performed.

5.4. **At least once a month**, check roller chain tension. Correct tension is movement back and forth of the roller chain, when pushed and pulled by hand, between 3/4" and 1". Adjust top-plate bolts until correct tension is achieved.

5.5. **At least once a month**, oil roller chain using brush or spout can.

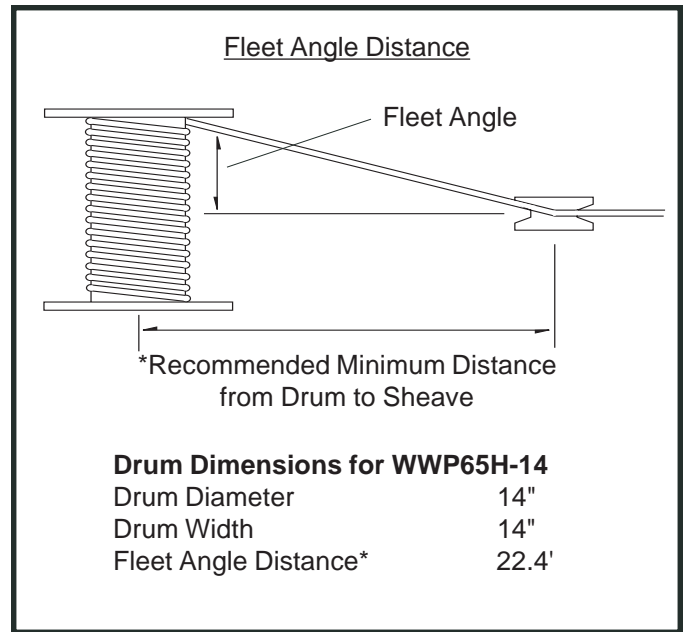
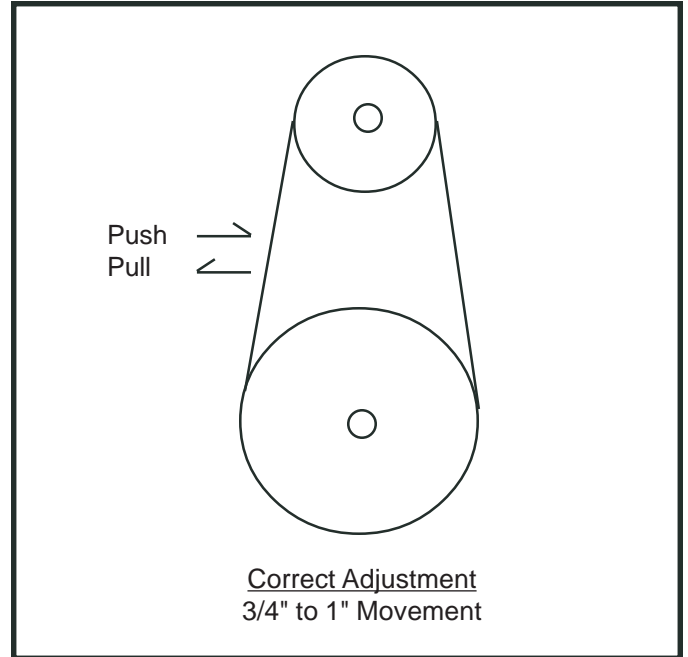

W. W. PATTERSON COMPANY

3 Riversea Road, Pittsburgh, PA 15233 • Phone (800) 322-2018 • Fax (412) 322-2785

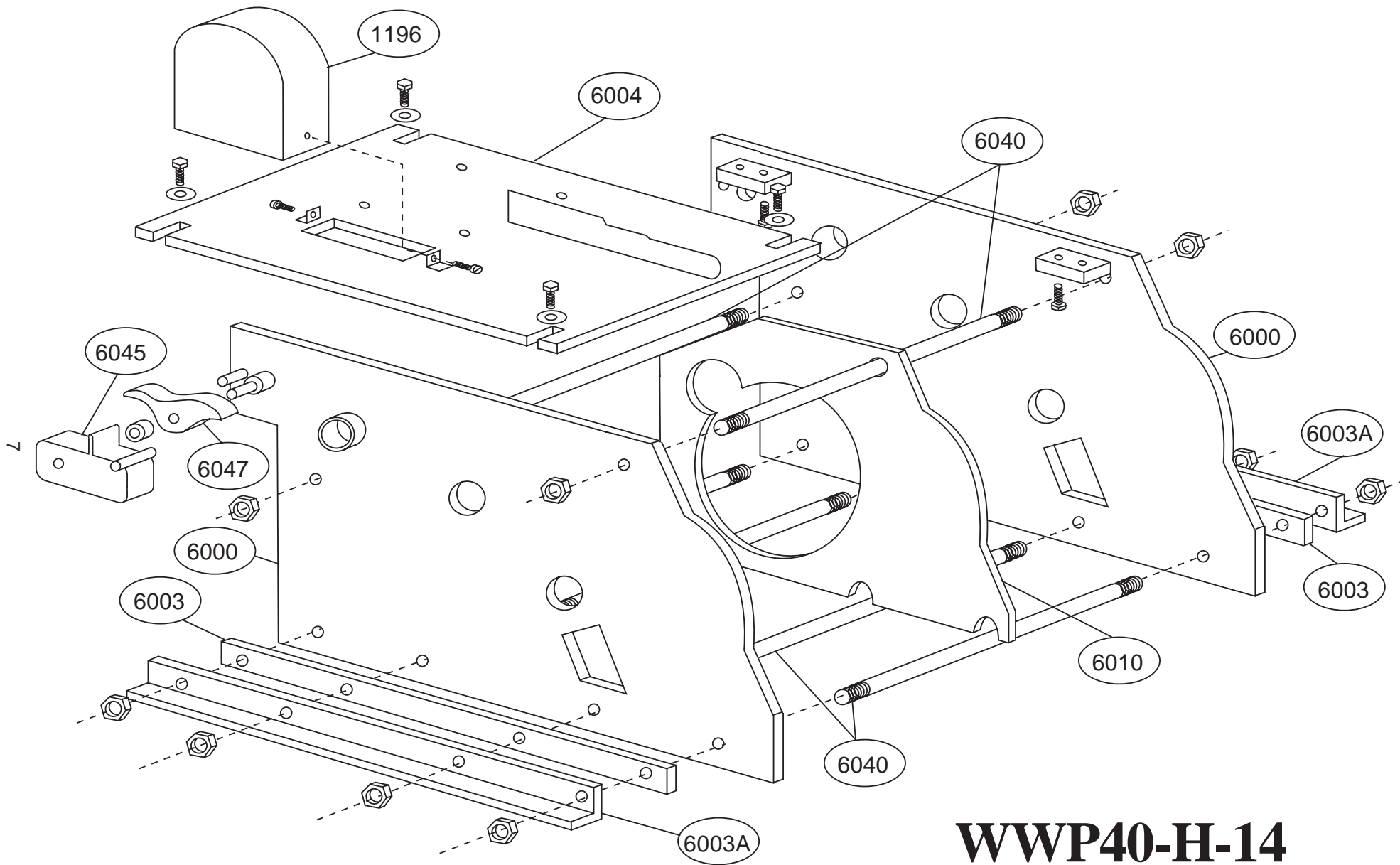

WWP40-H-14

Frame Components

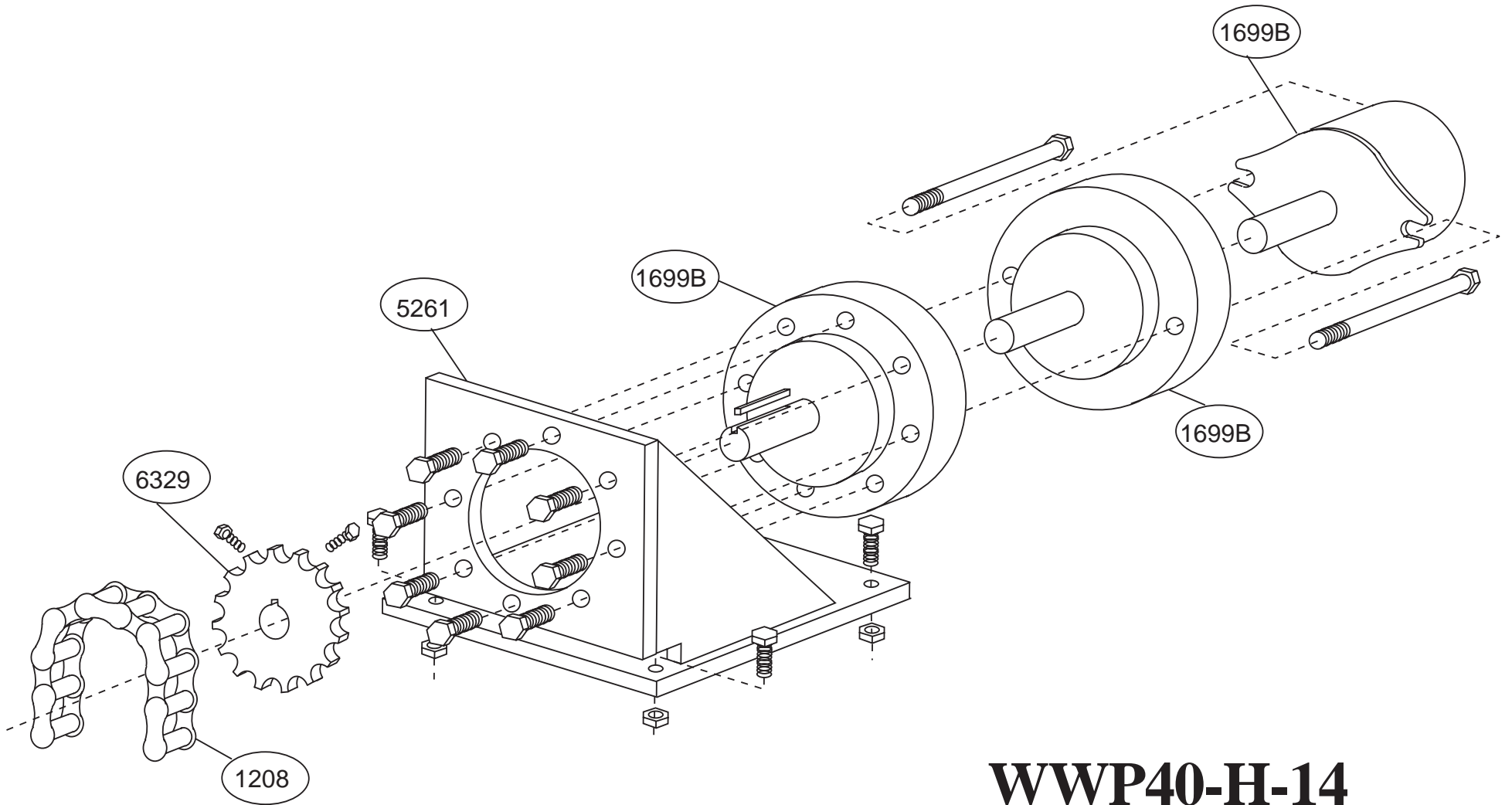

WWP40-H-14 Gear/Motor/Brake Components

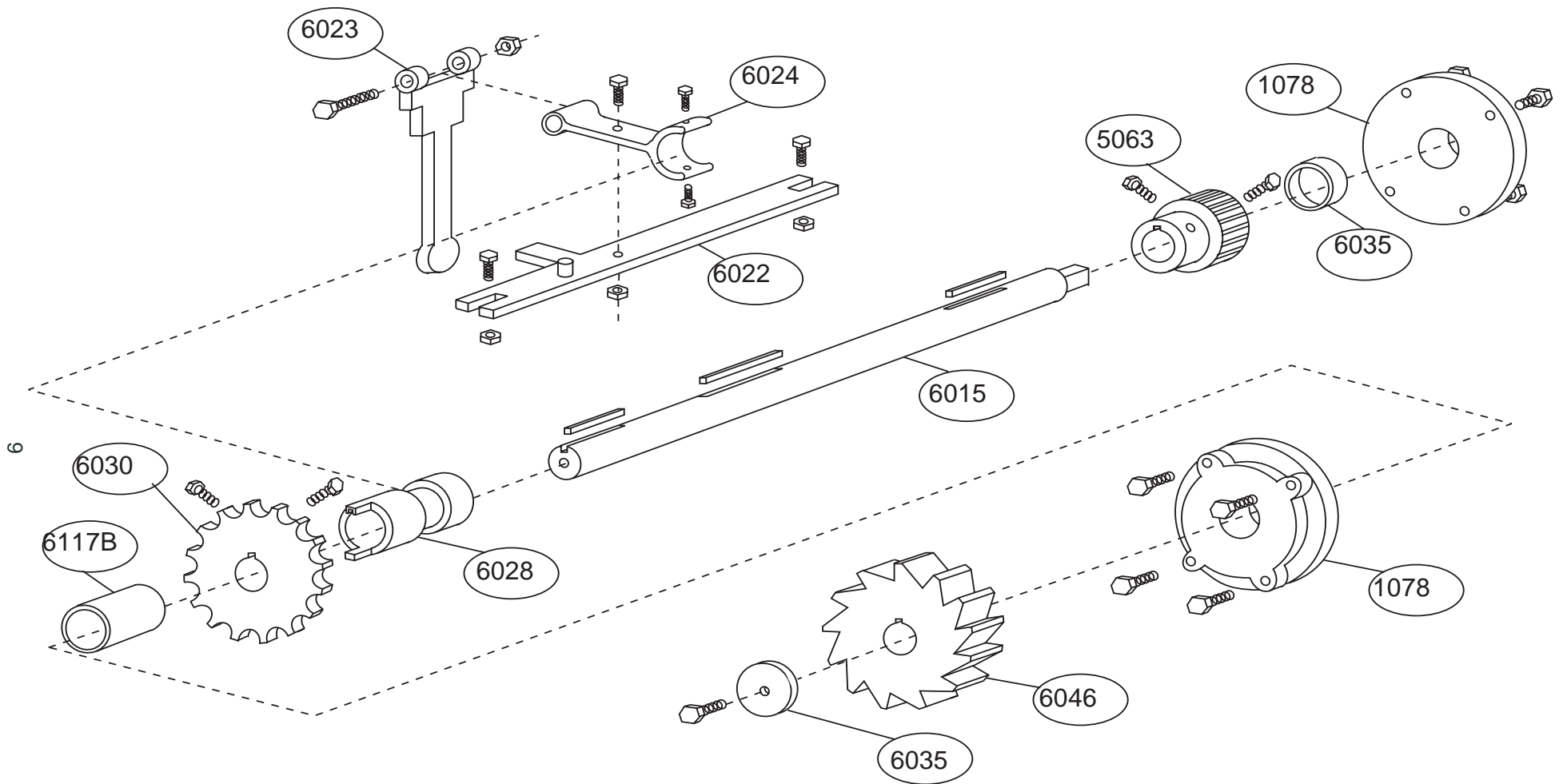

WWP40-H-14

#1 Shaft Components

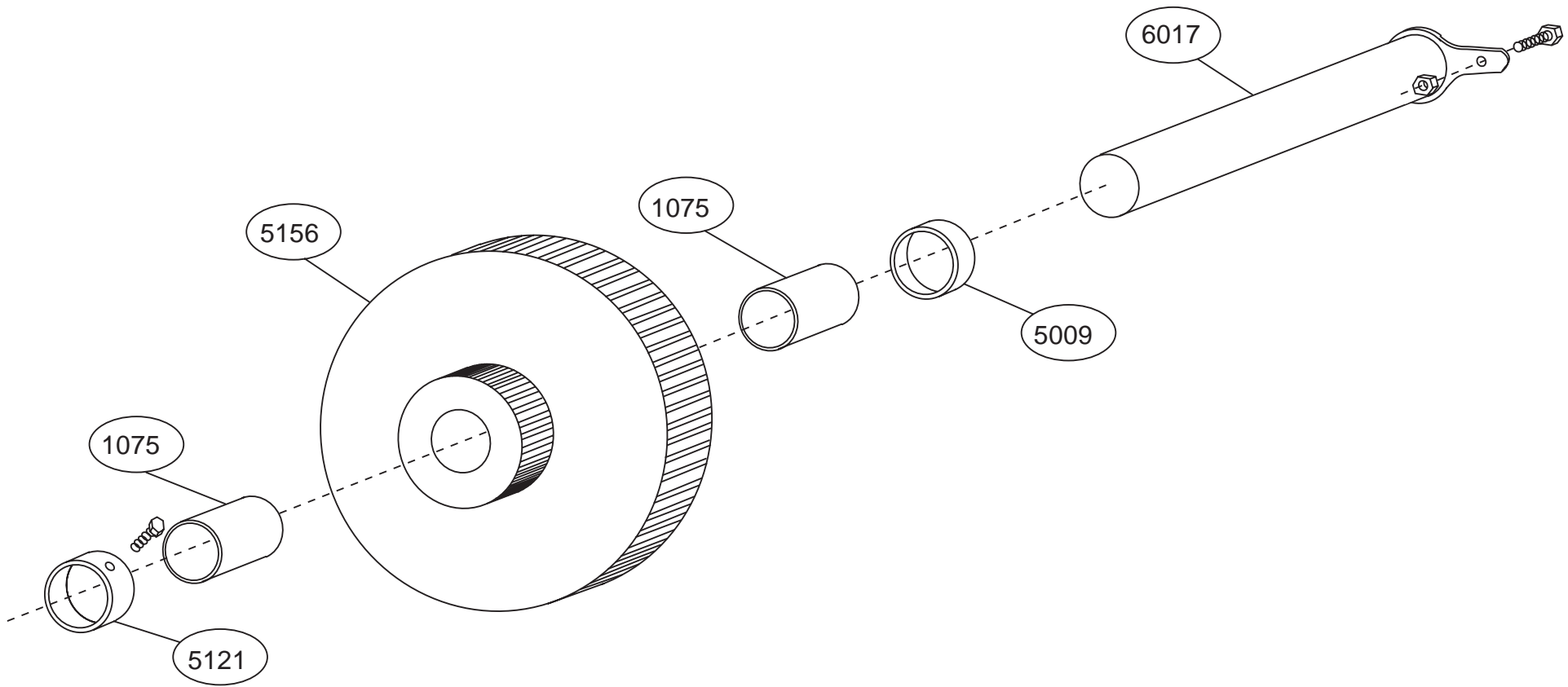

WWP40H-14 #2 Shaft Components

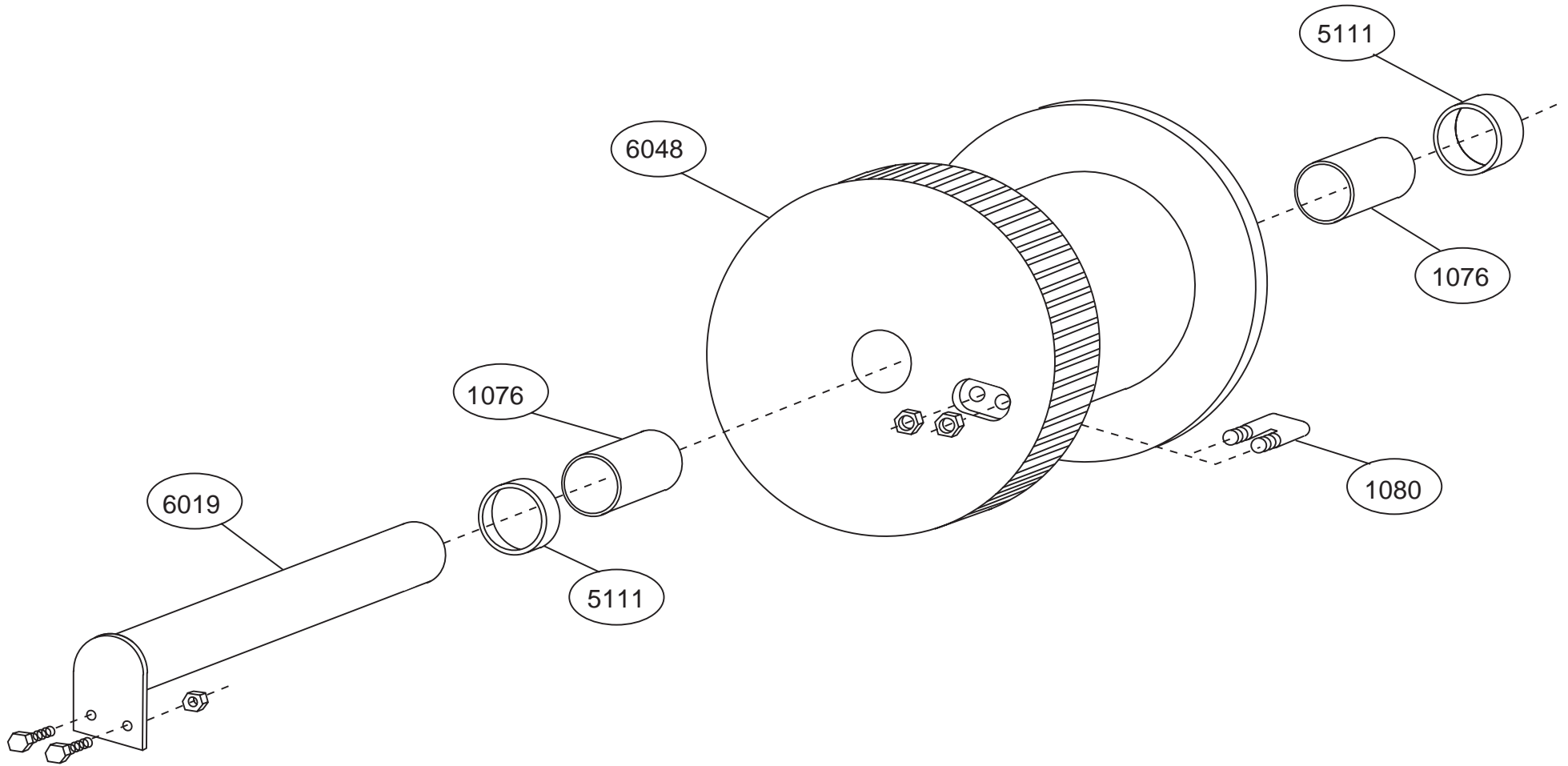

WWP40-H-14 #3 Shaft Components

WWP40-H-14 WINCH PARTS LIST

Frame Components		
<u>QUANTITY</u>	<u>DESCRIPTION</u>	<u>PART NUMBER</u>
2	Side Plate	6000
1	Rope Guard	6010
1	Locking Dog	6047
1	Counter Weight	6045
2	Foot Mount	6003
2	Angle Foot Mount	6003A
1	Motor Base Plate	6004
7	Seperator Tube/Tie Rod	6040
1	Sprocket Guard	1196

Gear/Motor/Brake Components		
<u>QUANTITY</u>	<u>DESCRIPTION</u>	<u>PART NUMBER</u>
1	Gear/Motor Complete */+	1166
1	Motor Only +	1167
1	Gear Box Only *	1168
1	Motor Sprocket	6056
1	Roller Chain	1205
4	Tie Down Bolts	1028
1	Brake Cover	1676
1	Brake - Complete **/+	1379

* When ordering, please note whether left-hand or right-hand.

** To order individual Stearns Brake components, refer to Stearns' Parts List included elsewhere in this manual.

+ When ordering, please note whether 230/460 volt or 208 volt.

WWP40-H-14 WINCH PARTS LIST

#1 Shaft Components

<u>QUANTITY</u>	<u>DESCRIPTION</u>	<u>PART NUMBER</u>
1	Shaft	6015
1	Pinion Gear	5063
2	Roller Bearing	1078
1	Male Clutch	6028
1	Female Clutch/Sprocket	6030
1	Large Spacer	6035A
1	Shifter Yoke	6024
1	Pivot Bolt and Handle	6023
1	Support Bar	6022
2	Small Spacer	6035
1	Locking Dog Gear	6046

#2 Shaft Components

<u>QUANTITY</u>	<u>DESCRIPTION</u>	<u>PART NUMBER</u>
1	Shaft	6017
1	Combination Spur/Pinion Gear	5156
2	Bushing	1075
1	Retaining Collar	5121
1	Spacer	5009

#3 Shaft Components

<u>QUANTITY</u>	<u>DESCRIPTION</u>	<u>PART NUMBER</u>
1	Shaft	6019
1	Rope Drum	6048
2	Bushing	1076
2	Spacer	5111
1	Rope Clip	1080