



W. W. Patterson Company
3 Riversea Road
Pittsburgh, PA 15233
Phone: 800-322-2018
FAX: 412-322-2785

OPERATIONS/PARTS MANUAL
FOR
PATTERSON'S
MODEL # WWP75M-10
and all WIDE DRUM variations
of this HAND OPERATED WINCH.

Please fill in the following blanks and then keep this manual in a safe and convenient location. When calling with either questions or replacement part needs, always refer to the Model and Serial Number of the winch.

PART NUMBER: _____ **SERIAL NUMBER:** _____

DATE PURCHASED: _____

DISTRIBUTOR INFORMATION

NAME: _____

ADDRESS: _____

CITY: _____ **STATE:** _____ **ZIP:** _____

PHONE: _____ **FAX:** _____



IMPORTANT!

Prior to installing and operating the winch, please read this manual thoroughly and carefully. Keep this manual and all other instructions accessible at all times.

Although this manual will help you become familiarized with the operating procedures for the winch, it is by no means a substitute for proper training and the safe use of winches, barge rigging and other marine equipment. Because owners and operators are solely responsible for determining whether a particular usage is acceptable, only individuals trained in the proper use of winches, barge rigging and other marine equipment should operate winches.

The typical operational environment of winches includes very high forces, and the potential hazards associated with these forces should not be underestimated. Improper installation or misuse of the winch may result in injury to persons or cause equipment failure or damage.

ALWAYS OBSERVE THESE BASIC SAFETY PRECAUTIONS:

- Keep all fingers, loose clothing and any foreign objects away from winch while in operation.
- During operation of the winch, always remain to the side of the winch, slightly behind the handwheel.
- Never operate the winch from the front or when bystanders are in front of it.
- Operators and bystanders should stay clear of any load and the wire rope while the winch is operating.
- Under no circumstances, should any winch be used to move, raise or lower a person(s) or equipment.
- Do not operate the winch unless you have a firm stance on a non-slippery surface.
- Tension on the wire rope should be adjusted only by the proper use of the handwheel ratchet or the extension pipe. Do not stand or jump on either the handwheel spokes or the extension pipe or by any other means. Severe injury could result from such actions.
- Do not apply tension to the winch unless there are at least four complete wraps of rope on the drum.
- Never let go of the ratchet handle under tension. It will snap forward and can cause serious injury. Also, the ratchet extension can fly off the ratchet handle and cause injury, even at a distance.
- If tension on the wire rope is too much to be controlled with reasonable force by the operator, then maneuver the barges to relieve tension.
- Always place the ratchet handle in the forward resting position immediately after winch operation. Any other handle position is unsafe.
- Inspect the winch fully at least once a month for worn gears and pawls, cracked welds, and other damaged or worn parts. If any worn, cracked or damaged parts are found, stop use immediately and remove the winch from service until all appropriate repairs are completely made.

1 INSTALLATION

1.1. All winches must be installed on flat, rigid and non-slippery surfaces. Deck and structure must be strong enough to withstand the weight and holding capacity of the winch, and the forces likely to occur during operation.

1.2. Place the winch in the mounting area, in line with the direction of cable pull and with enough Fleet Angle Distance. (Refer to Diagram on Page 8.) Check to make sure there is enough clearance for proper operation by inserting the ratchet extension and swinging it through the complete arc.

1.3. Weld to deck along the complete length of both side plates. Use seal welding to protect the weld against corrosion. Remember, the weld has to be strong enough to withstand loads equal to, at least, the Ultimate Shock Load Capacity of the winch.

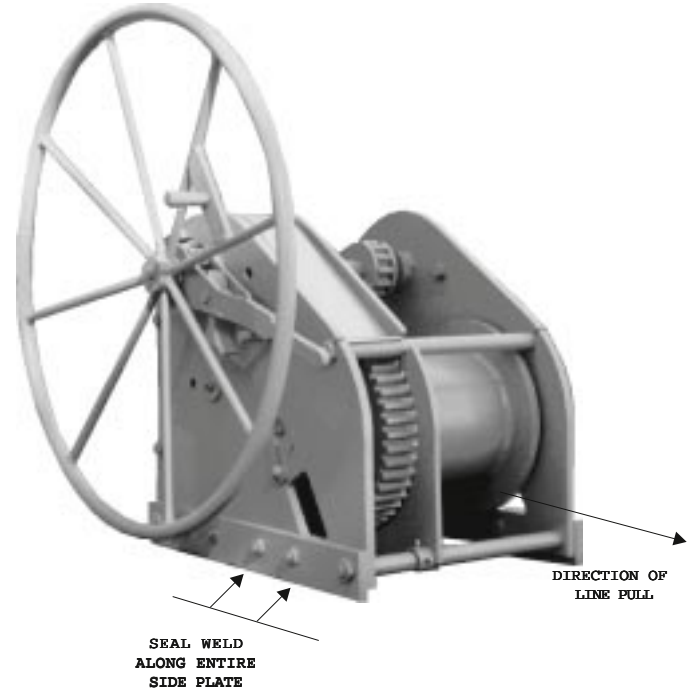

2. ATTACHING THE WIRE ROPE



2.1. Rotate the drum until the cable clamp nuts appear in the slot on the side plate. Using a standard socket wrench with extension, loosen the nuts.

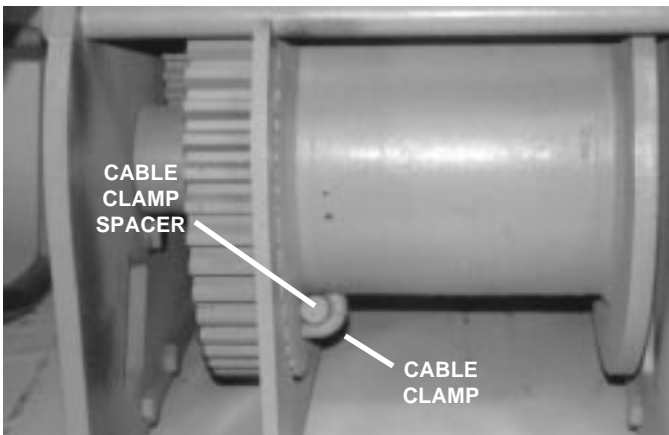

2.2. If installing a new winch, remove and discard the cable clamp spacer. If replacing worn out wire rope, remove the rope from the cable clamp and dispose of the wire rope properly. Insert the new wire rope from the front of the winch into the cable clamp until 3 to 4 inches of rope extends through the clamp. Tighten the nuts evenly.

WARNING! PERIODICALLY RETIGHTEN THE NUTS ON THE CABLE CLAMP TO INSURE CABLE IS SNUG AGAINST DRUM FLANGE.



2.3. Place the load-holding dog into the teeth of the load-holding ratchet wheel. This helps to prevent the wire rope from paying out.

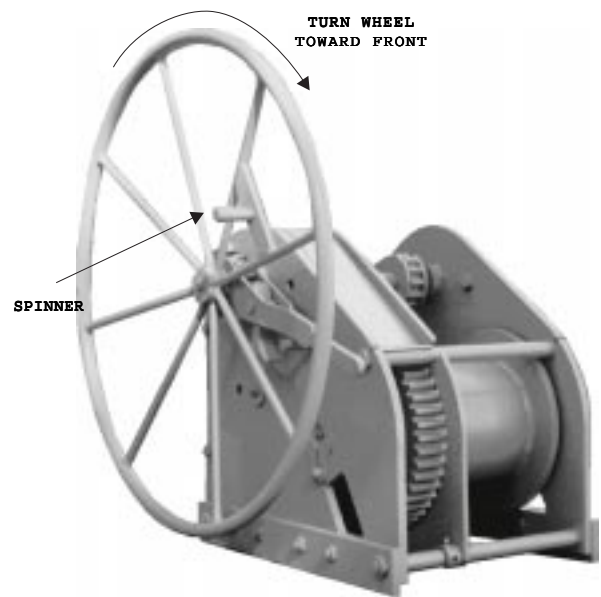

2.4. Turn the handwheel toward the front of the winch to spool the wire rope onto the drum. Maintain enough tension on the rope to be sure the first coil begins snugly against the side of the drum and each successive coil is snug against the previous coil. Check to make sure the rope is reeled in from the bottom of the drum. (If the winch is equipped with a spinner, the spinner may be used to spool the rope more quickly.)

2.5. Continue to spool the rope until at least four (4) complete coils of wire rope are snugly on the drum.

WARNING! FOUR (4) COMPLETE COILS OF THE WIRE ROPE MUST BE ON THE DRUM AT ALL TIMES IN ORDER FOR THE WINCH TO ATTAIN ITS FULL HOLDING CAPACITY AND PRIOR TO TENSION BEING APPLIED.

3. REELING IN TO TENSION

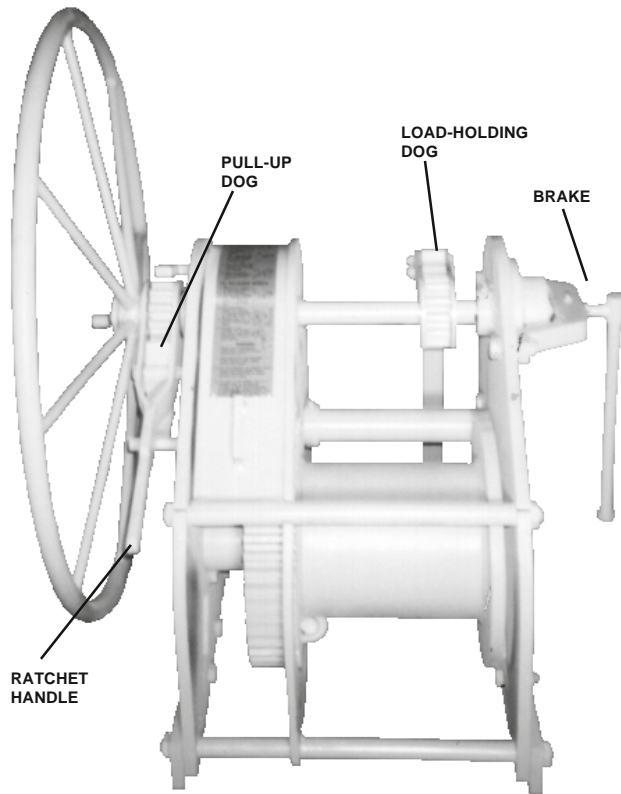

3.1. Make sure that the load-holding dog is engaged in the load-holding-ratchet wheel and that the brake is completely disengaged.

3.2. Turn the handwheel toward the front of the winch to tighten the load.

3.3. When the handwheel can no longer be turned, additional tension can be added to the wire rope by the use of an extension pipe on the ratchet handle.

WARNING! SHOULD THE WINCH BE EQUIPPED WITH A SPOKED HANDWHEEL, DO NOT JUMP OR STAND ON THE HANDWHEEL SPOKES TO TIGHTEN THE WIRE ROPE OR ADJUST TENSION. SEVERE INJURY COULD RESULT!

3.4. Slip an extension pipe over the end of the ratchet handle.

3.5. Raise the extension pipe.

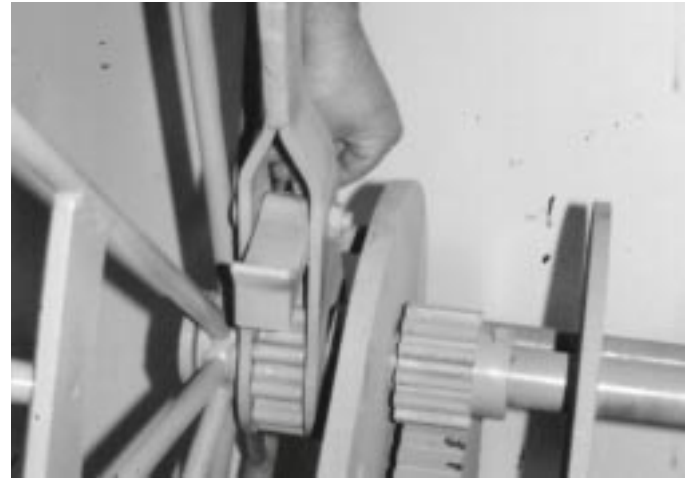

3.6. Manually check to make sure the pull-up dog is completely engaged in the ratchet wheel.

3.7. Apply downward force to the extension pipe. Repeat steps 3.5 through 3.7 until desired tension is achieved.

WARNING! DO NOT JUMP ON THE EXTENSION PIPE! SEVERE INJURY COULD RESULT! ADDITIONALLY, DO NOT PUT EXCESSIVE WEIGHT OR FORCE ON THE EXTENSION PIPE.

3.8. When desired tension is achieved, disengage the pull-up dog and make sure the ratchet handle is in the forward resting position. The load-holding dog will continue to hold tension on the wire rope.

WARNING! DO NOT OPERATE THE WINCH UNDER EXTREME TENSION. IF TENSION IS TOO MUCH TO BE CONTROLLED WITH REASONABLE FORCE BY THE OPERATOR, THEN MANEUVER THE BARGES TO RELIEVE TENSION.

3.9. Remove the extension pipe and store it in its proper place.

WARNING! NEVER LEAVE THE EXTENSION PIPE ON THE RATCHET HANDLE. NEVER LEAVE THE PULL-UP DOG ENGAGED IN THE RATCHET WHEEL. SEVERE INJURY COULD RESULT!

4 RELEASING THE LOAD

4.1. Make sure the areas around the winch and load are clear.

4.2. Make sure the ratchet handle and pull-up dog have been completely disengaged from the ratchet wheel. Also make sure the ratchet handle is in the forward resting position.

WARNING! ALWAYS PLACE THE RATCHET HANDLE IN THE FORWARD RESTING POSITION IMMEDIATELY AFTER WINCH OPERATION. ANY OTHER POSITION IS UNSAFE.



4.3. Move to the brake side of the winch.

4.4. Turn the brake handle toward the back of the winch to tighten the brake disk against the winch side plate.

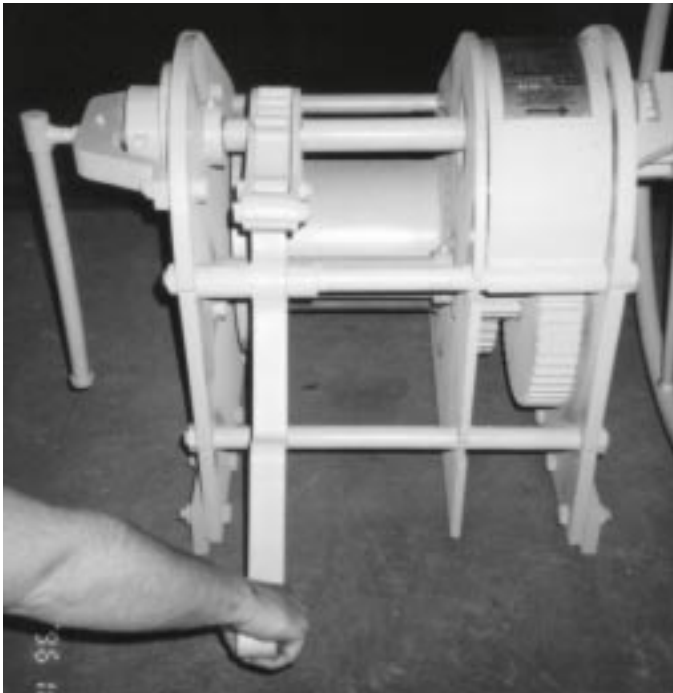

4.5. Lift the release lever in the rear of the winch. The load-holding dog will partially disengage.

4.6. If the brake has not been engaged, the load-holding dog will not disengage when the release lever is lifted. If this should happen, see Section 5: INCORRECT RELEASE OF THE LOAD.

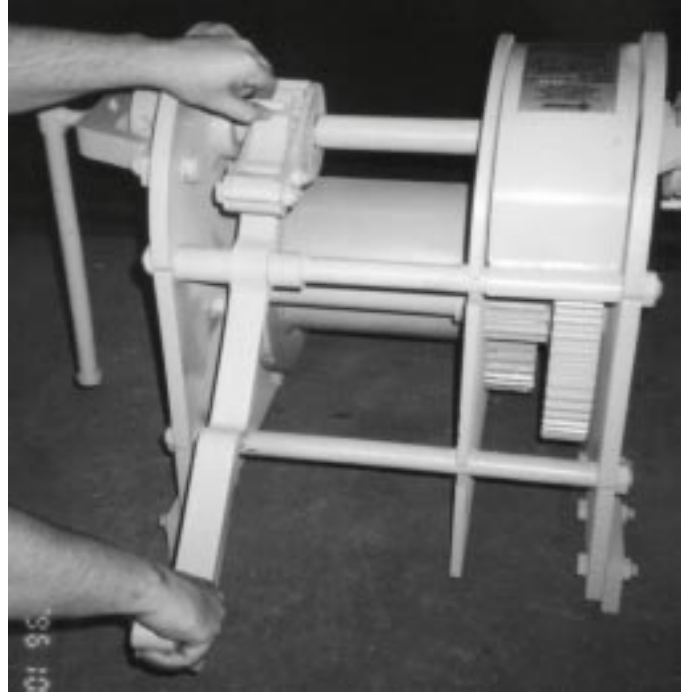

4.7. Rotate the load-holding dog out of the ratchet wheel so that it is completely free of and away from the ratchet-wheel teeth.

4.8. Lower the release lever to its vertical resting position.

4.9. Return to the brake side of the winch and slowly turn the brake handle toward the front of the winch. The slow release of the brake allows a controlled pay-out of the wire rope. Use the brake handle to tighten or to loosen the brake in order to maintain desired pay-out control.

5. INCORRECT RELEASE OF THE LOAD

In the event the release lever is lifted before the brake disk has been tightened against the winch side plate, the operator will be unable to disengage the load-holding dog and release the load.

5.1. Slip the extension pipe over the end of the release lever.

5.2. Push down on the extension pipe to return the release lever to its vertical resting position.

WARNING! DO NOT JUMP OR STAND ON THE RELEASE LEVER TO LOWER IT! SEVERE INJURY COULD RESULT!

5.3. Once the release lever is in its vertical resting position, follow the proper load-releasing sequence (see Section 4: RELEASING THE LOAD).

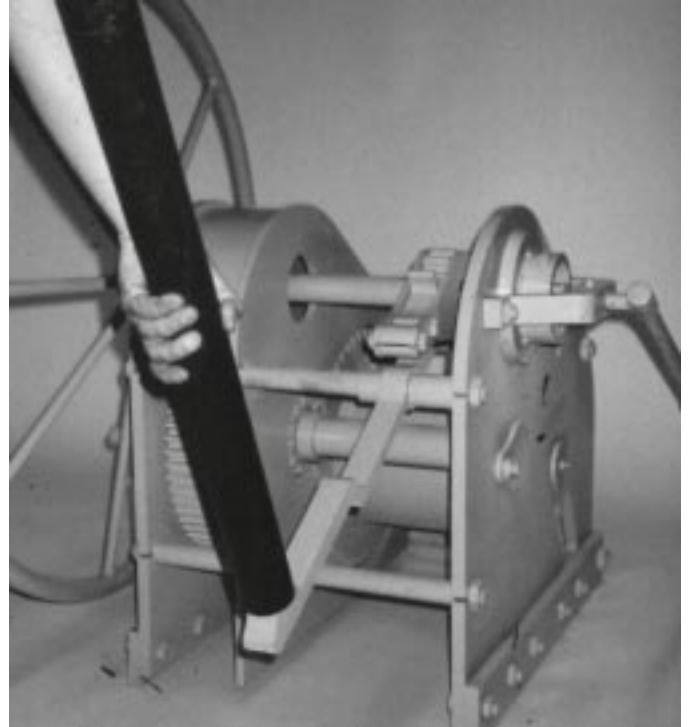

6. LUBRICATION AND INSPECTION

6.1. All grease fittings should be lubricated **once a week** using a **POLYUREA** grease such as ALTRA 500 EP2.

6.2. All gear teeth should be coated **once a week** with heavy-duty gear grease.

6.3. Inspect the winch carefully and completely at least **once a month** for worn gears and pawls, cracked welds, and other damaged or worn parts. If any worn, cracked or damaged parts are found, stop use immediately and remove the winch from service until all appropriate repairs are completely performed.

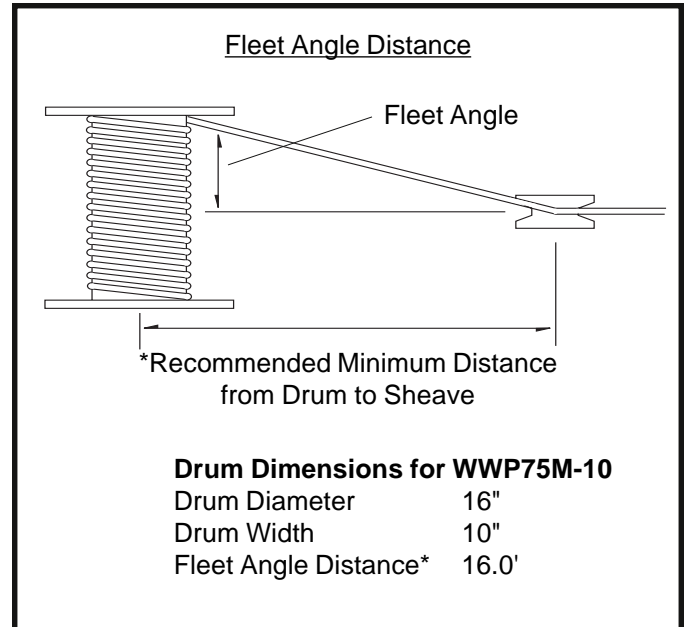

W. W. PATTERSON COMPANY

3 Riversea Road, Pittsburgh, PA 15233 • Phone (800) 322-2018 • Fax (412) 322-2785

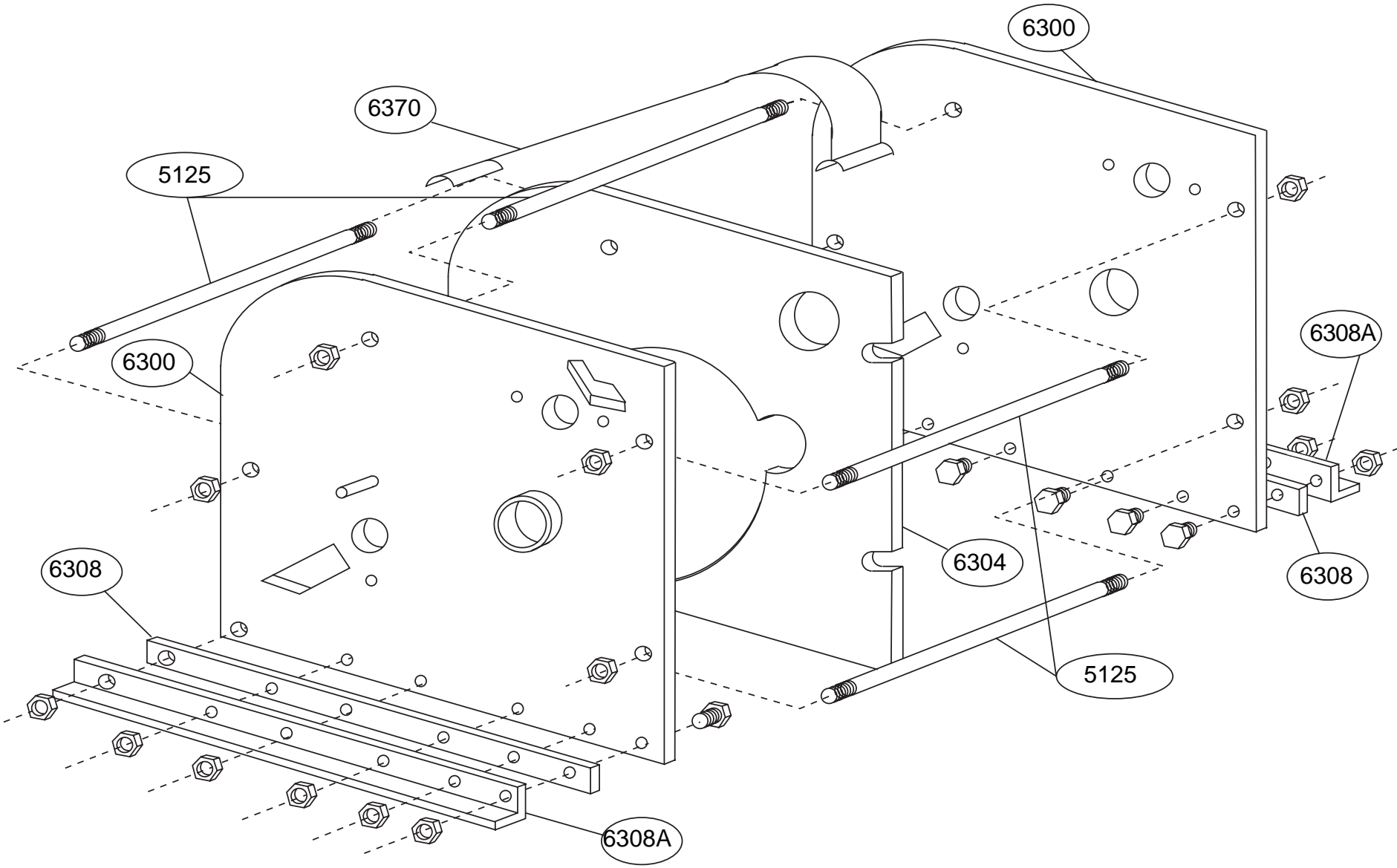

WWP75M-10 Frame Components

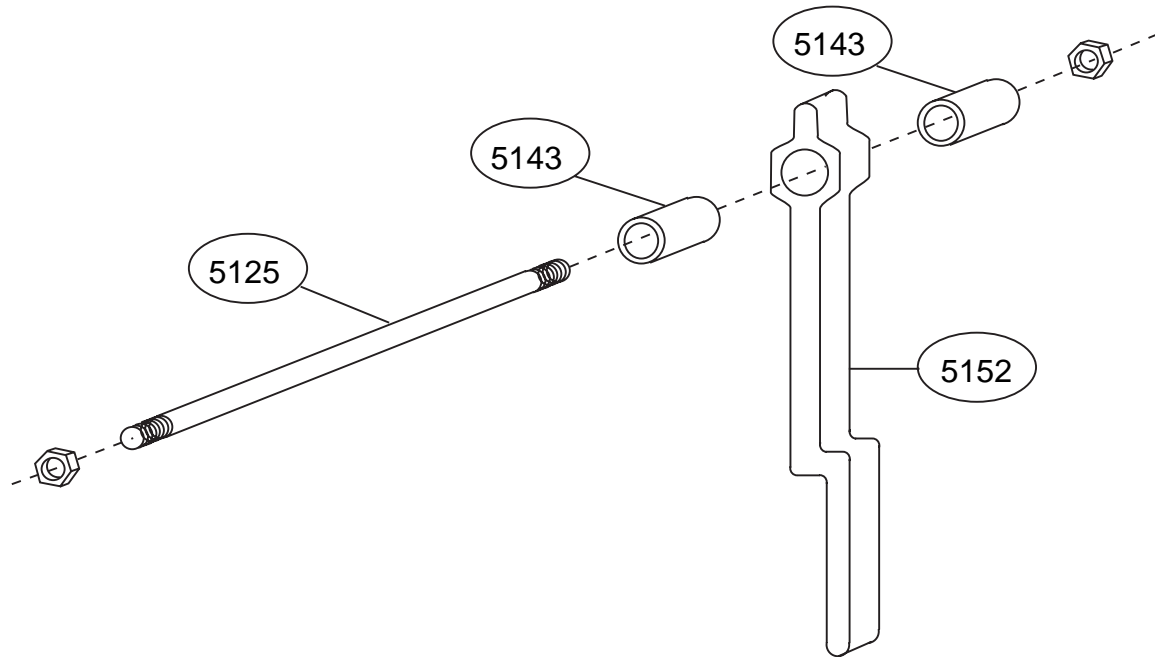

WWP75M-10 Cam Lever Components

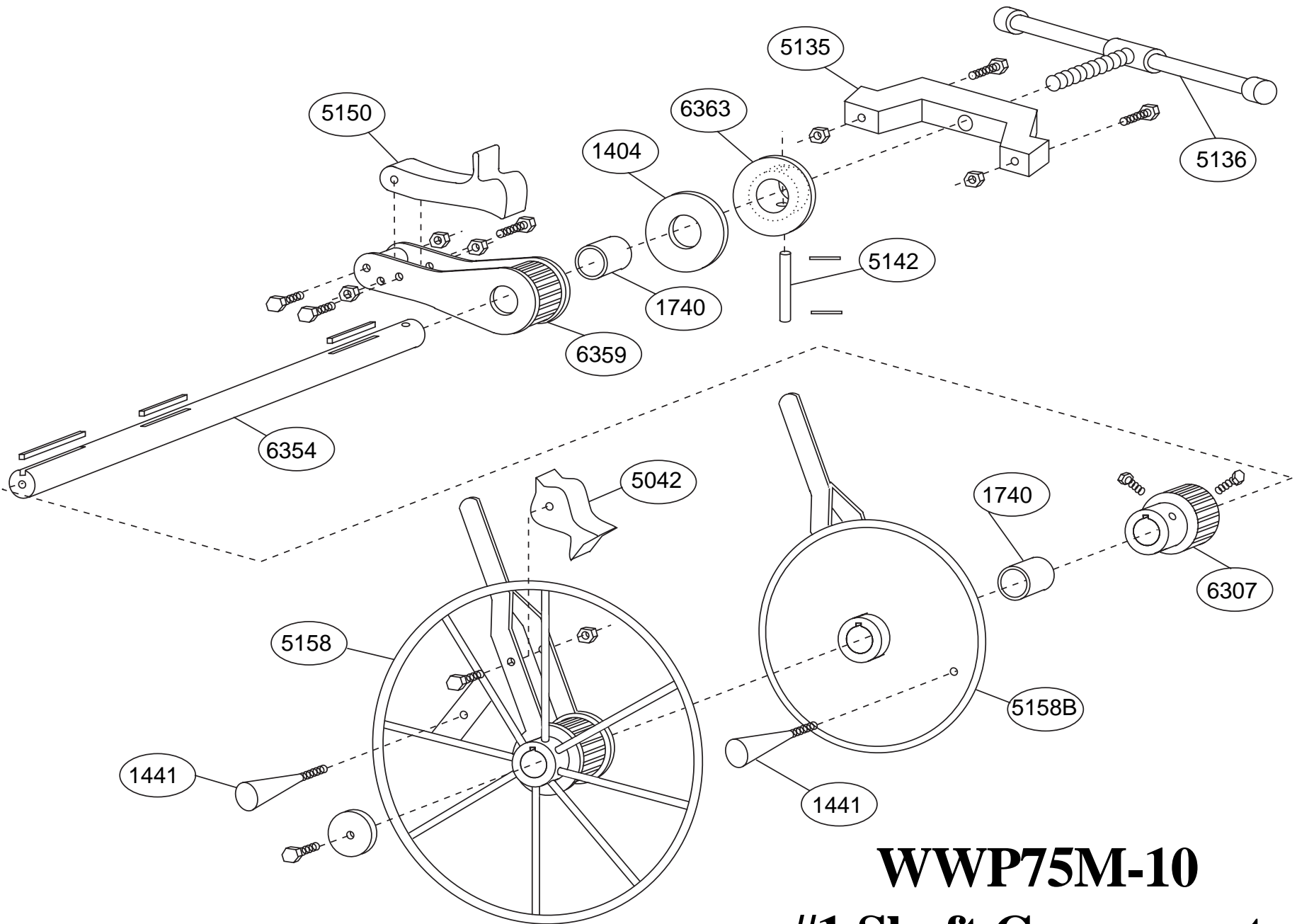

WWP75M-10

#1 Shaft Components

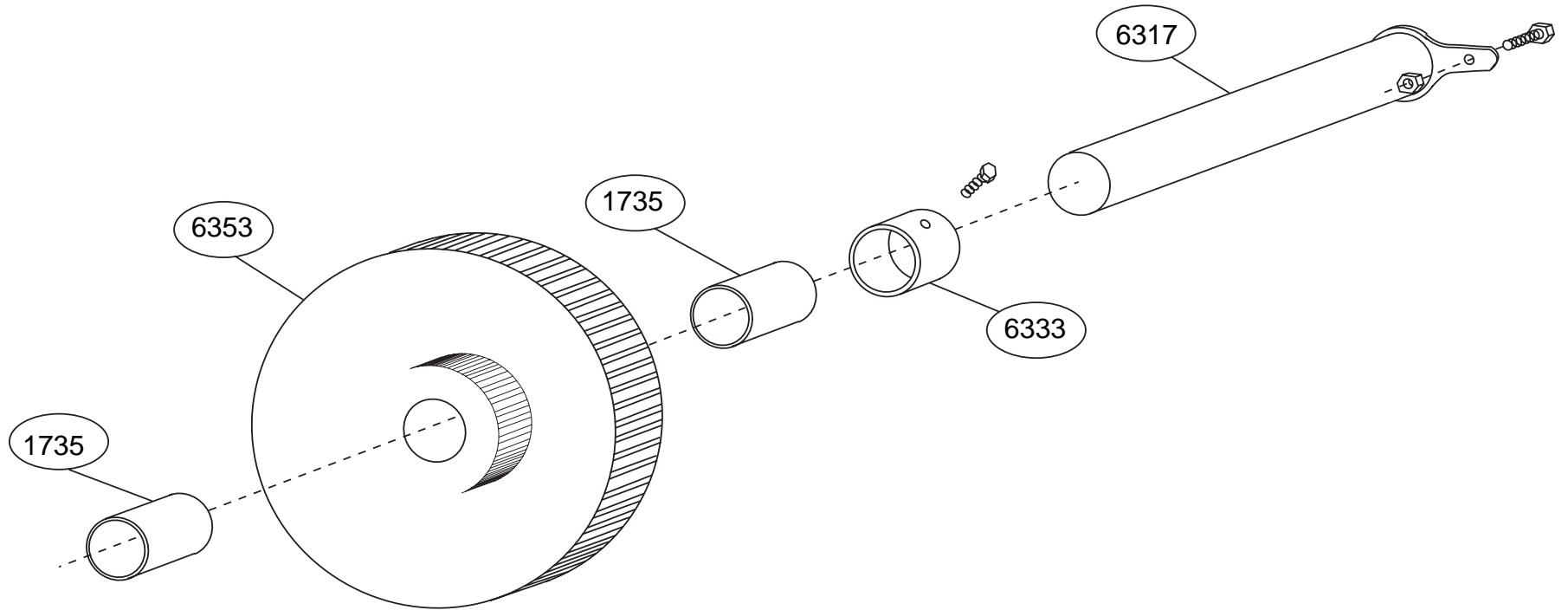

WWP75M-10 #2 Shaft Components

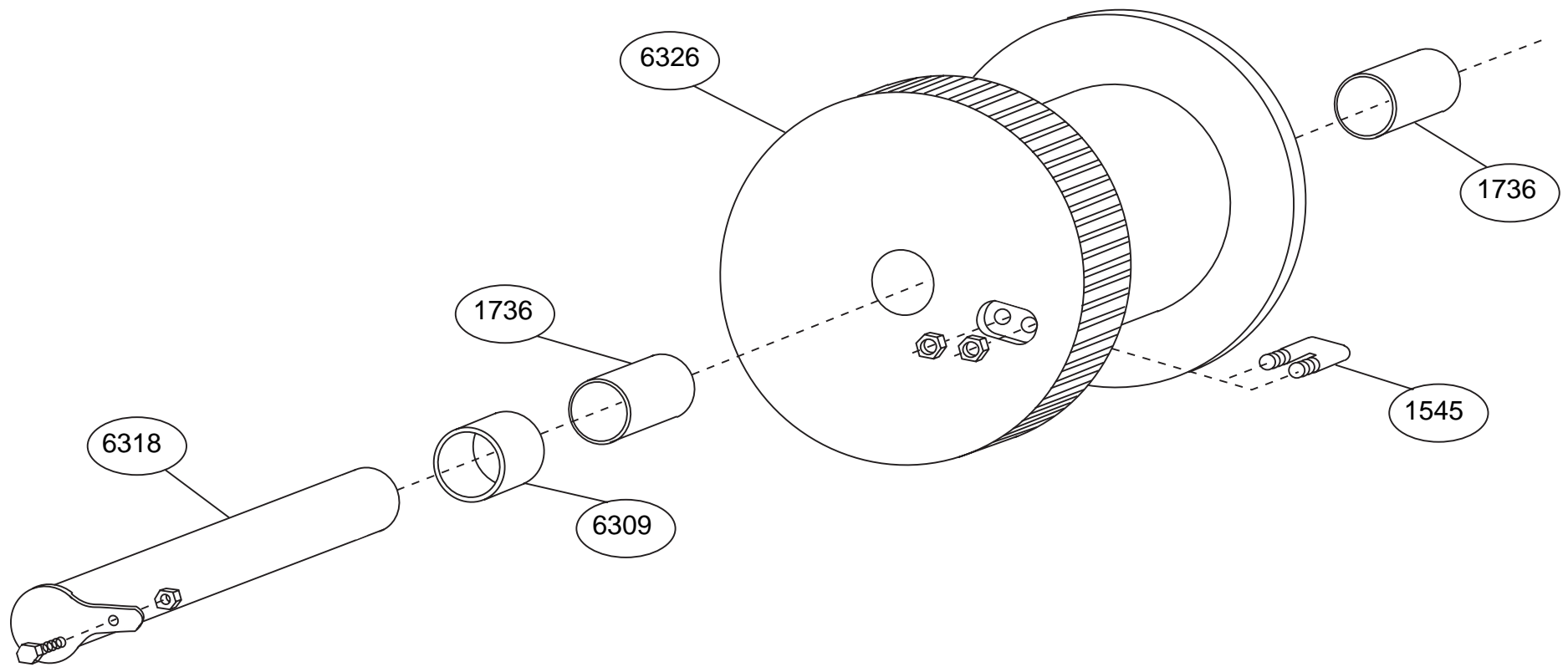

WWP75M-10 #3 Shaft Components

WWP75M-10 WINCH PARTS LIST

Frame Components

<u>QUANTITY</u>	<u>DESCRIPTION</u>	<u>PART NUMBER</u>
2	Side Plate	6300
1	Gear Guard	6304
1	Gear Shroud	6370
2	Foot Mount	6308
2	Angle Foot Mount	6308A
4	Separator Tube/Tie Rod	5125

Cam Lever Components

<u>QUANTITY</u>	<u>DESCRIPTION</u>	<u>PART NUMBER</u>
1	Cam Lever	5152
2	Spacer	5143

#1 Shaft Components

<u>QUANTITY</u>	<u>DESCRIPTION</u>	<u>PART NUMBER</u>
1	Dished Handwheel Assembly	5158
1	Solid Handwheel Assembly	5158B
1	Pull Up Ratchet Pawl	5042
1	Spinner Knob	1441
1	Shaft	6354
1	Pinion Gear	6307
1	Ratchet Lock Assembly	6359
1	Ratchet Lock Pawl	5150
2	Bushing	1740
1	Friction Brake Plate	6363
1	Friction Brake Pin	5142
1	Friction Brake Liner	1404
1	Friction Brake Bracket	5135
1	Vise Handle Assembly	5136

WWP75M-10 WINCH PARTS LIST

#2 Shaft Components

<u>QUANTITY</u>	<u>DESCRIPTION</u>	<u>PART NUMBER</u>
1	Shaft	6317
1	Combination Spur/Pinion Gear	6353
2	Bushing	1735
1	Retaining Collar	6333

#3 Shaft Components

<u>QUANTITY</u>	<u>DESCRIPTION</u>	<u>PART NUMBER</u>
1	Rope Drum	6326
1	Drum Shaft	6318
2	Drum Bushing	1736
1	Spacer	6309
1	Rope Clip	1545